

TECHNICAL GUIDE

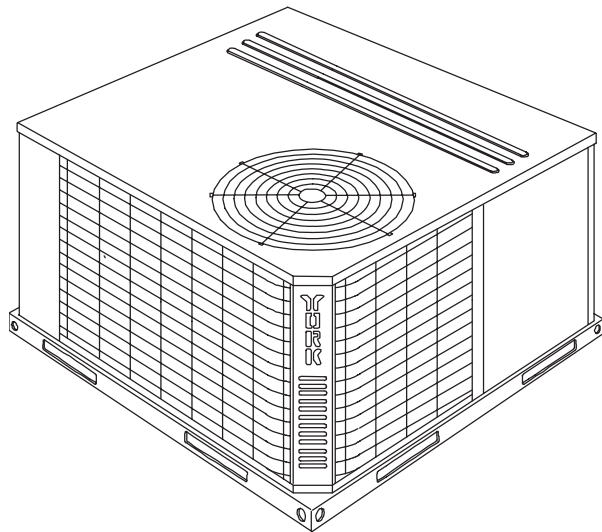

Heating and Air Conditioning



AFFINITY™ SERIES

SINGLE PACKAGE HEAT PUMPS

**BHP024 THRU 060
2 THRU 5 NOMINAL TONS
13 SEER**

FACTORY MOUNTED TXV

DESCRIPTION

York® Affinity™ Series packaged heat pumps are designed for outdoor installation. Only utility and duct connections are required at the point of installation.

Field-installed electric heater accessories are available to provide electric heat, if required.

STANDARD FEATURES / BENEFITS

OPERATING EFFICIENCY

All units provide high operating efficiencies of 13 SEER, 3.3 COP or greater, and 7.7 HSPF. All efficiencies exceed legislated minimum levels.

ON SITE FLEXIBILITY

All model sizes share a common, compact design cabinet with a single footprint. The installer has the flexibility of setting one curb or pad and placing the proper tonnage unit after the internal load has been determined. Field convertible duct connections, from side shot to down shot, allows the installer greater flexibility and the need to carry less inventory.

LOWER INSTALLATION COST

Installation time and costs are reduced by easy power and control wiring connections. The small base dimension means less space is required on the ground or roof. Plus, the installer can fit this unit between the wheel wells of full size pick-up truck. All models are under 500 pounds.

All units are completely wired, charged with R-22 and tested prior to shipment. Unique test stations, are used to insure product quality. Refrigerant charge, and component part numbers are verified via computers at manufacturing point. Vital run test statistics, such as, system pressure, motor currents, air velocity and temperature unit vibration are monitored and recorded by the system to insure unit performance.

Equal size, side supply and return duct connections allow easy hook-up of ducts to match low crawl spaces without transition pieces.

UTILITY CONNECTIONS MADE EASY

Electrical utility knockouts are provided through the bottom, as well as the side of the unit. Utility connections can be made quickly and with a minimum amount of field labor. A field supplied and field installed electrical disconnect switch must be installed.

CONVERTIBLE AIRFLOW DESIGN

The bottom duct openings are covered when they leave the factory. They are ready for a side supply / side return application. If a bottom supply / bottom return application is desired, you simply remove the two panels from the bottom of the unit and place them in the side supply / side return duct openings. No panel cutting is required and no accessory panel is necessary. Convertible airflow design allows maximum field flexibility and minimum inventory.

CONDENSATE PAN

A non-corrosive, long-lasting, water-tight pan is positioned below the evaporator coil to collect and drain all condensate; less collection of stagnate condensate will build-up. The condensate pan conforms to ASHRAE 62-89 standards (Ventilation for Acceptable Indoor Air Quality).

CONDENSATE DRAIN

The heavy duty, 1/2 inch NPTI copper connection is more tolerable during installation and is more durable over time. The connection is rigidly mounted to assure proper fit and leak tight seal.

DURABLE FINISH

With a heavy duty cabinet made of powder-painted, galvanized steel, the neutral color blends into surrounding areas. The powered paint provides a better paint to steel bond, which resists corrosion and rust creep. The special primer formulas and glossy earth tone finish insure less fading when exposed to sunlight and offers a more attractive on site appearance. This paint finish exceeds ASTM-B117 standards for 1000 hours salt spray rating, the highest in the industry.

FULL PERIMETER BASE RAILS

The easily removable base rails provide a solid foundation for the entire unit and protects the unit during shipment. The rails provide fork lift access from all sides. Rigging holes are, provided also so that an overhead crane can be used to place the unit on a roof. On applications when the unit is placed on a pad, the base will keep the unit off the pad to deter corrosion. On applications where height is limited, the 2-3/8 inch high base rails may be removed on location.

MORE ATTRACTIVE APPEARANCE

A single piece "Water Shed" top cover containing a top discharge condenser fan arrangement requires less square footage on installation and provides a wider variety of installations. The one piece design adds greater water integrity. Rounded corners with water drip edges add to the attractive appearance. The cabinet panels have a non-fibrous insulation that reduces insulation fibers into conditioned area.

TOP DISCHARGE

The top discharge condenser fan does not disrupt neighboring areas and does not dry-out vegetation surrounding the unit. The warm air from the top mounted fan is blown up away from the structure and any landscaping. This allows compact location on multi-unit applications.

OUTDOOR COIL GRILLE

A multi-piece totally enclosed, rigidly mounted outdoor coil grille provides protection from objects and personnel after installation. It also provides protection during transit and installation.

LOW OPERATING SOUND LEVEL

The upward air flow carries the normal operating noise up and away from the living area. The rigid top panel effectively isolates any motor sound. Isolator mounted compressor and the rippled fins of the condenser coil, muffle the normal fan motor and compressor operating sounds. The unique formed base pan also aids in sound alterations with its "Super-Structure" design. This design strategically places embossments in the pan for optimum strength and rigidity.

FAN SYSTEM

All models operate over a wide range of design conditions with a 5 speed direct drive indoor blower motor. These units easily match all types of applications and provide greater on site flexibility to match comfort requirements.

SIMPLE CONTROL CIRCUIT

A low voltage printed circuit board contains a low voltage terminal strip. The electrical control box is not located in the compressor compartment. All wiring internal to the unit is color/number coded.

CONTROLS

Reliable demand defrost control provides defrost. Defrost control also provides an "X" terminal to provide a 24 volt signal for room thermostat "LED" indication of unit lockout, plus, built in 5 minute anti-short cycle protection.

PROTECTED COMPRESSOR

The compressor is internally protected against high pressure and temperature. This is accomplished by the simultaneous operation of high pressure relief valve and a temperature sensor which protects the compressor, if undesirable operating conditions occur.

EXCLUSIVE COIL DESIGN

Grooved copper tubes and enhanced aluminum fin construction improves heat transfer for maximum efficiency and durability.

LOW MAINTENANCE

Long life, permanently lubricated condenser and evaporator fan motor bearings, need no annual maintenance. Blower assembly can be easily cleaned by the unique "Slip Track" slide-out blower assembly.

SECURED SERVICE ACCESS PORTS

Protected, externally mounted, re-usable service access ports are provided on both the high and low lines for ease of evacuating and charging the system.

EASY SERVICE ACCESS

A large, single hinged panel covers the electrical controls and makes servicing easy. The blower compartment has an additional large panel with a built-in handle tab. Removing this panel will allow the blower assembly to slide-out for easy removal for maintenance and ease of trouble shooting.

REPLACEMENT PARTS

The installer has no need to carry an inventory of unique parts or needs special training to replace any of the components parts for these units. All are easily obtained from Source 1 or other major part houses.

FIELD-INSTALLED ACCESSORIES

ECONOMIZER DOWN DISCHARGE / SUPPLY KIT

Modulating integrated economizer provides simultaneous operation between the mechanical cooling and economizer operation. Independent blade design insures proper control and less than 1% leak rate. Includes hood and mesh bird screen filter integrated into the hood, dry bulb sensor and relief damper. Sepa-

rate field accessories of single enthalpy and dual enthalpy are also available.

SINGLE ENTHALPY SENSOR

Sensor replaces dry bulb sensor standard in economizer kit. Provides improved economizer operation by sensing the dry bulb temperature from outdoors, plus the enthalpy content of the outdoor air.

DUAL ENTHALPY SENSOR

Additional sensor to single enthalpy sensor. Sensor selects both the return air temperature dry bulb and humidity, in conjunction with the single enthalpy, to determine the most economical mix. Single Enthalpy sensor also required.

UPGRADE PRESSURE PACKAGE

Contains screw in type High pressure, Low Pressure/Loss of Charge switch, freeze protection switch and lockout relay. Switches are placed onto existing Schrader ports located in the unit by furnished adapters. When abnormal conditions are sensed through the pressure switches, the unit will lock out, preventing any further operation until reset or problem is corrected. Package agency approved.

HAIL GUARD KIT

Kit contains protected grilles made of expanded aluminum grilles with full perimeter 1-1/2 inch frame. Sloped hoods are also included to assure maximum protection.

FILTER / FRAME KIT (SINGLE PHASE ONLY)

Kit contains the necessary hardware to field install return air filters into the base unit. Pre-cut filter racks and appropriate cleanable standard size filters are shipped in one kit (1" filter is supplied). This kit is available for single phase horizontal or vertical duct application only. Standard in all 3 Phase models.

MOTORIZED FRESH AIR DAMPER

Designed for duct mounted side return and unit mounted down shot return applications. Damper capable of providing 0% thru 50% of outdoor air (field supplied). Closes on power loss, includes hood and screen assembly.

RECTANGLE TO ROUND ADAPTERS

Kit includes one supply and one return air rectangle to round duct adapter. Adapters are preformed and designed to fit over current duct openings on the base unit. Transition is from 15" square to 14" round.

ROOF CURBS

NRCA approved curbs provide proper fit to base unit for rooftop installations. Curbs are designed to be assembled through hinge pins in each corner. Kit also provides seal strip to assure a water tight seal. Eight and 14 inch high roof curbs are available.

MANUAL OUTDOOR DAMPER

Provides 0% thru 50% outdoor air capability (field adjustable). Designed for duct mounted side return and

unit mounted down shot applications. Includes hood and screen assembly.

WALL THERMOSTAT

The units are designed to operate with 24-volt electronic and electro-mechanical thermostats. All units can operate with single stage heat / single stage cool thermostats - with or without the economizer.

ELECTRIC HEATERS

Each heater package provides easy installation of electric heat strips. Slide in design with plug in harness and agency approved. Heaters are available from 5.0 KW sizes and are designed for single point and dual connection.

TABLE OF CONTENTS

Description	1	Heating Capacities - 4 Ton (BHP048)	20
Standard Features / Benefits	1	Heating Capacities - 5 Ton (BHP060)	20
Field-installed Accessories	3	Side & Bottom Supply Air Blower Performance	21
Unit Cut Away	5	Additional Static Resistance	21
Ratings	5	Typical Field Wiring Diagram	22
Physical Data	5	Electrical Data (13 Seer Heat Pump / Electric Heat)	22
Cooling Capacities - 2 Ton (BHP024)	6	Application Data	24
Cooling Capacities - 2-1/2 Ton (BHP030)	8	Center Of Gravity And Weights	24
Cooling Capacities - 3 Ton (BHP036)	10	Unit Clearances	24
Cooling Capacities - 3-1/2 Ton (BHP042)	12	Unit Dimensions	25
Cooling Capacities - 4 Ton (BHP048)	14	Typical Applications	26
Cooling Capacities - 5 Ton (BHP060)	16	Roof Curb Dimensions	27
Heating Capacities - 2 Ton (BHP024)	18	Typical Wiring Diagram (208/230-1-60 Power Supply)	28
Heating Capacities - 2-1/2 Ton (BHP030)	18	Typical Wiring Diagram (208/230-3-60 Power Supply)	29
Heating Capacities - 3 Ton (BHP036)	19	Typical Wiring Diagram (460/575-3-60 Power Supply)	30
Heating Capacities - 3-1/2 Ton (BHP042)	19	Mechanical Specifications.....	31

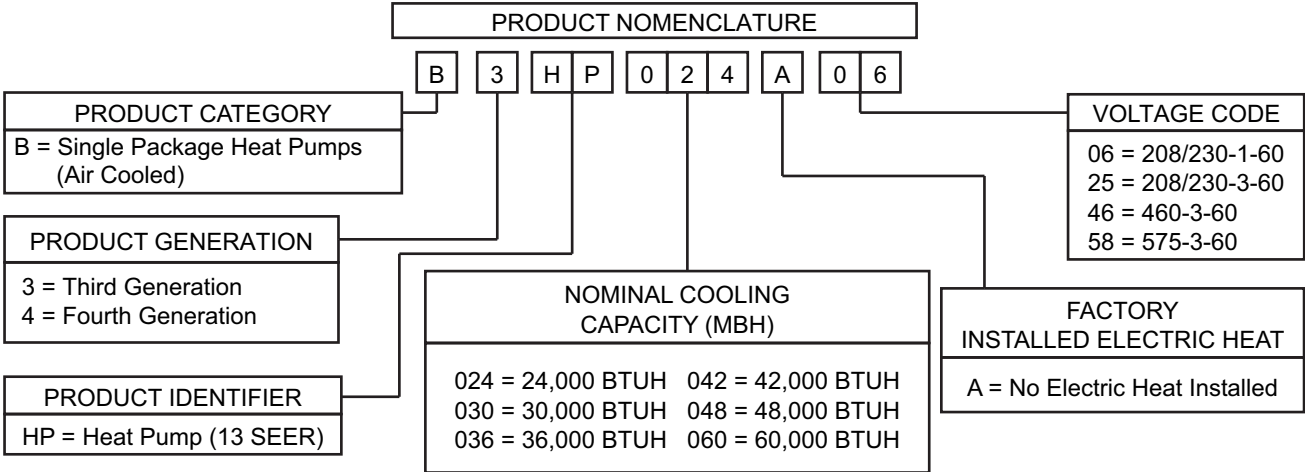

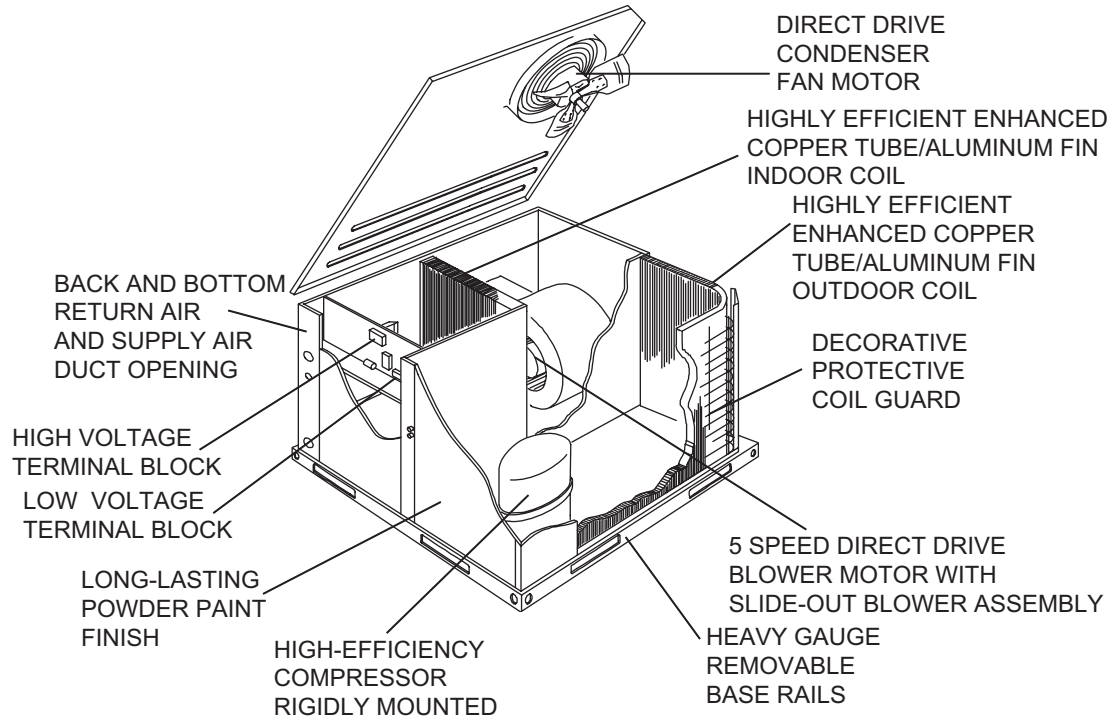

FIGURE 1 - UNIT CUT AWAY

TABLE 1: RATINGS

MODEL BHP	COOLING CAPACITY ¹ 80 / 67-95°F			HSPF ¹	SOUND RATING ² (dbels)	NET HEATING CAPACITY				AVAILABLE ELECTRIC HEAT NOMINAL CAPACITY KW	
	MBH	SEER	EER			@47°F		@17°F		SINGLE PHASE	THREE PHASE
						MBH	COP	MBH	COP		
024	24.4	13.0	11.8	7.7	79	21.8	3.40	11.0	2.00	5.0, 7.5, 10.0	N / A
030	30.0	13.0	11.3	7.7	77	28.2	3.40	16.5	2.20	5.0, 7.5, 10.0, 15.0	10.0, 15.0
036	35.0	13.0	11.3	7.7	77	32.0	3.30	18.9	2.20	5.0, 7.5, 10.0, 15.0	10.0, 15.0
042	42.0	13.0	11.3	7.7	83	42.0	3.40	23.0	2.20	10.0, 15.0	10.0, 15.0
048	47.0	13.0	11.3	7.7	82	45.0	3.30	25.8	2.20	10.0, 15.0, 20.0, 25.0	10.0, 15.0, 20.0, 25.0
060	55.0	13.0	11.2	7.7	83	56.5	3.30	33.2	2.15	10.0, 15.0, 20.0, 25.0	10.0, 15.0, 20.0, 25.0

1. Certified in accordance with the Unitary Small Equipment certification program, which is based on ARI Standard 210/240.

2. Rated in accordance with ARI Standard 270.

SEER = Seasonal Energy Efficiency Ratio - the total cooling output in BTU's during a normal annual usage period for cooling divided by the total electric power input in watt-hours during the same period.

COP = Coefficient of Performance - the total heating capacity provided by the refrigeration system, including circulating fan heat but excluding supplementary resistance (BTU's per hour) divided by the total electric input (watts) x 3.412.

TABLE 2: PHYSICAL DATA

MODELS		BHP					
		024	030	036	042	048	060
INDOOR BLOWER	CENTRIFUGAL BLOWER (Dia. x Wd. in.)	10 X 8	10 X 8	11 x 10	11 x 10	11 X 10	11 X 10
	FAN MOTOR HP	1/2	1/2	3/4	3/4	3/4	1
INDOOR COIL	ROWS DEEP	2	3	3	3	3	3
	FINS PER INCH	15	13	15	16	16	16
	FACE AREA (Sq. Ft.)	4.38	4.38	4.38	5.63	5.63	5.63
OUTDOOR FAN	PROPELLER DIA. (in.)	22	22	22	22	22	22
	FAN MOTOR HP	1/4	1/4	1/4	1/4	1/4	1/2
	NOM. CFM TOTAL	1,800	1,800	2,400	2,400	3,000	3,000
OUTDOOR COIL	ROWS DEEP	1	1	2	2	2	2
	FINS PER INCH	20	20	20	20	20	20
	FACE AREA (Sq. Ft.)	11.7	11.7	11.7	16.4	16.4	16.4
CHARGE	REFRIGERANT 22 (lbs./oz.)	5 / 5	5 / 15	8 / 8	9 / 14	12 / 0	10 / 4
FILTER	FACE AREA (Sq. Ft. / Qty. / Size)	4.28 / 2 / 14 x 22					
COMPRESSOR	Hermetic Type, Qty. = 1	Reciprocating	Scroll	Scroll	Reciprocating	Scroll	Scroll

TABLE 3: COOLING CAPACITIES - 2 TON (BHP024)

Air on Evaporator Coil		Temperature of Air on Condenser Coil																		
CFM	WB (°F)	Total Capacity ¹ (MBh)	Total Input (kW) ²	Sensible Capacity (MBh)						Total Capacity ¹ (MBh)	Total Input (kW) ²	Sensible Capacity (MBh)								
				Return Dry Bulb (°F)								Return Dry Bulb (°F)								
				90	85	80	75	70	65			90	85	80	75	70	65			
		75°F									85°F									
600	77	32.2	1.8	15.1	12.3	9.4	-	-	-	30.4	1.9	14.8	11.9	9.1	-	-	-			
	72	29.3	1.8	18.6	15.8	12.9	10.1	-	-	27.5	1.8	18.1	15.3	12.4	9.6	-	-			
	67	26.3	1.7	22.1	19.3	16.4	13.6	10.7	-	24.6	1.8	21.5	18.6	15.8	12.9	10.1	-			
	62	24.1	1.7	24.1	22.4	19.6	16.7	13.9	11.0	22.5	1.8	22.5	21.5	18.7	15.8	13.0	10.1			
	57	23.4	1.7	23.4	23.4	20.4	17.6	14.7	11.9	22.2	1.8	22.2	22.2	19.4	16.5	13.7	10.8			
700	77	33.0	1.8	16.6	13.6	10.3	-	-	-	31.3	1.9	16.7	13.2	9.8	-	-	-			
	72	30.1	1.8	20.8	17.4	14.0	10.7	-	-	28.3	1.9	20.2	16.8	13.5	10.1	-	-			
	67	27.1	1.7	25.0	21.2	17.8	14.5	11.1	-	25.3	1.9	23.7	20.5	17.1	13.8	10.4	-			
	62	24.8	1.7	24.8	24.0	21.3	17.9	14.6	11.2	23.1	1.8	23.1	22.7	20.3	16.9	13.5	10.2			
	57	24.1	1.7	24.1	24.1	22.2	18.8	15.5	12.1	22.8	1.8	22.8	22.8	21.0	17.7	14.3	10.9			
800	77	33.9	1.8	18.1	15.0	11.1	-	-	-	32.1	1.9	18.6	14.5	10.6	-	-	-			
	72	30.9	1.8	22.9	19.1	15.2	11.3	-	-	29.1	1.9	22.3	18.4	14.5	10.6	-	-			
	67	27.8	1.8	27.8	23.2	19.3	15.4	11.5	-	26.0	1.9	26.0	22.4	18.5	14.6	10.7	-			
	62	25.5	1.7	25.5	25.5	23.0	19.1	15.2	11.3	23.8	1.9	23.8	23.8	21.9	18.0	14.1	10.2			
	57	24.7	1.7	24.7	24.7	24.0	20.1	16.2	12.3	23.4	1.9	23.4	23.4	22.7	18.8	14.9	11.0			
900	72	31.7	1.8	25.2	20.8	16.4	12.0	-	-	29.7	2.0	24.5	20.0	15.6	11.2	-	-			
	67	28.6	1.8	28.6	25.2	20.8	16.4	12.0	-	26.6	1.9	26.6	24.3	19.8	15.4	11.0	-			
	62	26.2	1.8	26.2	26.2	24.9	20.5	16.1	11.6	24.3	1.9	24.3	24.3	23.4	18.9	14.5	10.1			
	57	25.4	1.8	25.4	25.4	25.0	20.6	16.2	11.7	23.9	1.9	23.9	23.9	23.6	19.1	14.7	10.3			
	72	32.5	1.8	27.5	22.6	17.6	12.6	-	-	30.4	2.0	26.6	21.7	16.7	11.7	-	-			
1000	67	29.3	1.8	29.3	27.3	22.4	17.4	12.4	-	27.2	2.0	27.2	26.2	21.2	16.2	11.3	-			
	62	26.8	1.8	26.8	26.8	26.8	21.9	16.9	11.9	24.9	1.9	24.9	24.9	24.9	19.9	14.9	9.9			
	57	26.1	1.8	26.1	26.1	26.1	21.1	16.1	11.2	24.4	1.9	24.4	24.4	24.4	19.5	14.5	9.5			
			95°F									105°F								
	600	77	28.7	1.9	14.4	11.5	8.7	-	-	-	23.9	2.1	16.7	13.9	11.0	-	-	-		
72		25.8	1.9	17.6	14.8	11.9	9.1	-	-	22.6	2.1	18.4	15.6	12.7	9.9	-	-			
67		22.9	1.9	20.8	18.0	15.1	12.3	9.4	-	21.3	2.1	20.1	17.3	14.4	11.6	8.7	-			
62		20.9	1.9	20.9	20.6	17.8	14.9	12.1	9.2	19.4	2.0	19.4	19.3	16.9	14.0	11.2	8.3			
57		20.9	1.9	20.9	20.9	18.3	15.5	12.6	9.8	19.6	2.0	19.6	19.6	17.1	14.2	11.4	8.5			
700	77	29.5	2.0	16.8	12.8	9.4	-	-	-	24.5	2.1	18.2	15.3	12.0	-	-	-			
	72	26.5	2.0	19.6	16.3	12.9	9.5	-	-	23.2	2.1	19.7	17.2	13.8	10.4	-	-			
	67	23.6	2.0	22.5	19.8	16.4	13.0	9.7	-	21.9	2.1	21.3	19.0	15.7	12.3	8.9	-			
	62	21.5	2.0	21.5	21.4	19.3	15.9	12.5	9.2	20.0	2.1	20.0	19.9	18.3	14.9	11.6	8.2			
	57	21.5	1.9	21.5	21.5	19.9	16.5	13.1	9.7	20.1	2.1	20.1	20.1	18.6	15.2	11.8	8.4			
800	77	30.3	2.1	19.2	14.0	10.1	-	-	-	25.2	2.2	19.6	16.8	12.9	-	-	-			
	72	27.2	2.1	21.7	17.8	13.9	10.0	-	-	23.8	2.2	21.0	18.8	14.9	11.0	-	-			
	67	24.2	2.1	24.2	21.6	17.7	13.8	9.9	-	22.4	2.2	22.4	20.8	16.9	13.0	9.1	-			
	62	22.1	2.0	22.1	22.1	20.8	16.9	13.0	9.1	20.5	2.2	20.5	20.5	19.8	15.9	12.0	8.1			
	57	22.0	2.0	22.0	22.0	21.4	17.5	13.6	9.7	20.6	2.2	20.6	20.6	20.0	16.1	12.2	8.4			
900	72	27.7	2.1	23.7	19.3	14.8	10.4	-	-	24.2	2.2	22.1	19.8	15.9	11.5	-	-			
	67	24.6	2.1	24.6	23.3	18.9	14.4	10.0	-	22.8	2.2	22.8	21.9	18.1	13.6	9.2	-			
	62	22.5	2.0	22.5	22.5	21.8	17.4	13.0	8.5	20.8	2.2	20.8	20.8	20.4	16.0	11.6	7.1			
	57	22.4	2.0	22.4	22.4	22.1	17.7	13.2	8.8	20.9	2.2	20.9	20.9	20.6	16.2	11.8	7.3			
	72	28.2	2.1	25.7	20.7	15.8	10.8	-	-	24.5	2.3	23.3	20.8	16.9	12.0	-	-			
1000	67	25.1	2.1	25.1	25.0	20.1	15.1	10.1	-	23.1	2.3	23.1	23.1	19.2	14.3	9.3	-			
	62	22.9	2.1	22.9	22.9	22.9	17.9	12.9	8.0	21.1	2.2	21.1	21.1	21.1	16.1	11.2	6.2			
	57	22.8	2.1	22.8	22.8	22.8	17.9	12.9	7.9	21.2	2.2	21.2	21.2	21.2	16.3	11.3	6.3			

TABLE 3: COOLING CAPACITIES - 2 TON (BHP024) (Continued)

Air on Evaporator Coil		Temperature of Air on Condenser Coil															
CFM	WB (°F)	Total Capacity ¹ (MBh)	Total Input (kW) ²	Sensible Capacity (MBh)						Total Capacity ¹ (MBh)	Total Input (kW) ²	Sensible Capacity (MBh)					
				Return Dry Bulb (°F)								Return Dry Bulb (°F)					
				90	85	80	75	70	65			90	85	80	75	70	65
				115°F						125°F							
600	77	19.1	2.2	19.0	16.2	13.3	-	-	-	14.2	2.3	14.2	14.2	14.2	-	-	-
	72	19.3	2.2	19.2	16.4	13.5	10.7	-	-	16.1	2.3	16.1	16.1	14.4	11.5	-	-
	67	19.6	2.2	19.4	16.6	13.7	10.9	8.0	-	18.0	2.4	18.0	15.9	13.0	10.2	7.3	-
	62	17.9	2.2	17.9	17.9	15.9	13.1	10.2	7.4	16.5	2.3	16.5	16.5	15.0	12.2	9.3	6.5
	57	18.2	2.2	18.2	18.2	15.9	13.0	10.2	7.3	16.9	2.3	16.9	16.9	14.7	11.8	8.9	6.1
700	77	19.6	2.2	19.6	17.9	14.5	-	-	-	14.6	2.4	14.6	14.6	14.6	-	-	-
	72	19.9	2.3	19.8	18.1	14.7	11.4	-	-	16.5	2.4	16.5	16.5	15.6	12.3	-	-
	67	20.1	2.3	20.1	18.3	14.9	11.6	8.2	-	18.4	2.5	18.4	17.6	14.2	10.8	7.5	-
	62	18.4	2.3	18.4	18.4	17.3	14.0	10.6	7.2	16.9	2.4	16.9	16.9	16.4	13.0	9.6	6.3
	57	18.7	2.2	18.7	18.7	17.3	13.9	10.5	7.2	17.4	2.4	17.4	17.4	16.0	12.6	9.2	5.9
800	77	20.1	2.3	20.1	19.6	15.7	-	-	-	15.0	2.4	15.0	15.0	15.0	-	-	-
	72	20.4	2.3	20.4	19.8	15.9	12.0	-	-	17.0	2.5	17.0	17.0	16.9	13.0	-	-
	67	20.7	2.4	20.7	20.0	16.1	12.3	8.4	-	18.9	2.5	18.9	18.9	15.4	11.5	7.6	-
	62	18.9	2.3	18.9	18.9	18.7	14.9	11.0	7.1	17.4	2.5	17.4	17.4	17.4	13.8	10.0	6.1
	57	19.2	2.3	19.2	19.2	18.7	14.8	10.9	7.0	17.8	2.5	17.8	17.8	17.3	13.4	9.5	5.6
900	72	20.6	2.4	20.6	20.3	17.0	12.6	-	-	17.0	2.5	17.0	17.0	17.0	13.7	-	-
	67	20.9	2.4	20.9	20.6	17.3	12.8	8.4	-	19.0	2.6	19.0	19.0	16.5	12.0	7.6	-
	62	19.1	2.4	19.1	19.1	19.0	14.6	10.2	5.7	17.5	2.5	17.5	17.5	17.5	13.2	8.8	4.4
	57	19.4	2.3	19.4	19.4	19.1	14.7	10.3	5.9	17.9	2.5	17.9	17.9	17.7	13.2	8.8	4.4
1000	72	20.8	2.4	20.8	20.8	18.1	13.2	-	-	17.1	2.6	17.1	17.1	17.1	14.3	-	-
	67	21.1	2.4	21.1	21.1	18.4	13.4	8.4	-	19.2	2.6	19.2	19.2	17.5	12.6	7.6	-
	62	19.3	2.4	19.3	19.3	19.3	14.4	9.4	4.4	17.6	2.6	17.6	17.6	17.6	12.6	7.6	2.6
	57	19.6	2.4	19.6	19.6	19.6	14.7	9.7	4.7	18.0	2.6	18.0	18.0	18.0	13.1	8.1	3.1

1. These capacities are Net Capacities.
2. These ratings include the compressor, condenser fan and supply air blower motors.

TABLE 4: COOLING CAPACITIES - 2-1/2 TON (BHP030)

Air on Evaporator Coil		Temperature of Air on Condenser Coil															
CFM	WB (°F)	Total Capacity ¹ (MBh)	Total Input (kW) ²	Sensible Capacity (MBh)						Total Capacity ¹ (MBh)	Total Input (kW) ²	Sensible Capacity (MBh)					
				Return Dry Bulb (°F)								Return Dry Bulb (°F)					
				90	85	80	75	70	65			90	85	80	75	70	65
		75°F							85°F								
750	77	38.0	2.2	17.7	14.2	10.6	-	-	-	37.0	2.4	17.3	13.7	10.2	-	-	-
	72	35.9	2.2	22.9	19.3	15.8	12.2	-	-	34.3	2.4	22.1	18.6	15.0	11.4	-	-
	67	33.8	2.1	28.0	24.5	20.9	17.4	13.8	-	31.7	2.4	27.0	23.4	19.9	16.3	12.7	-
	62	30.2	2.1	30.2	27.4	23.9	20.3	16.8	13.2	28.6	2.3	28.6	26.7	23.1	19.5	16.0	12.4
	57	31.0	2.1	31.0	28.8	25.2	21.7	18.1	14.5	30.0	2.3	30.0	28.1	24.5	20.9	17.4	13.8
875	77	38.6	2.3	19.8	15.8	11.6	-	-	-	37.6	2.5	19.6	15.3	11.0	-	-	-
	72	36.5	2.2	25.7	21.4	17.2	13.0	-	-	34.9	2.4	24.7	20.5	16.3	12.1	-	-
	67	34.4	2.1	31.5	27.1	22.9	18.7	14.4	-	32.2	2.4	29.9	25.8	21.6	17.4	13.1	-
	62	30.7	2.1	30.7	29.3	26.1	21.9	17.7	13.5	29.1	2.4	29.1	28.1	25.1	20.9	16.7	12.5
	57	31.5	2.1	31.5	30.4	27.6	23.4	19.2	14.9	30.5	2.4	30.5	29.6	26.6	22.4	18.2	14.0
1000	77	39.2	2.3	21.9	17.4	12.6	-	-	-	38.3	2.5	21.9	16.8	11.9	-	-	-
	72	37.1	2.2	28.4	23.6	18.7	13.8	-	-	35.5	2.5	27.3	22.5	17.6	12.7	-	-
	67	34.9	2.1	34.9	29.7	24.8	20.0	15.1	-	32.8	2.4	32.8	28.2	23.3	18.4	13.6	-
	62	31.2	2.1	31.2	31.2	28.4	23.5	18.6	13.8	29.6	2.4	29.6	29.6	27.1	22.2	17.4	12.5
	57	32.0	2.1	32.0	32.0	29.9	25.1	20.2	15.4	31.0	2.4	31.0	31.0	28.8	23.9	19.0	14.2
1125	72	38.7	2.3	30.3	24.7	19.2	13.7	-	-	36.8	2.6	29.6	24.1	18.5	13.0	-	-
	67	36.4	2.2	36.4	31.0	25.5	19.9	14.4	-	34.0	2.6	34.0	30.0	24.5	19.0	13.4	-
	62	32.5	2.3	32.5	32.5	29.3	23.7	18.2	12.7	30.7	2.5	30.7	30.7	28.5	23.0	17.4	11.9
	57	33.4	2.3	33.4	33.4	30.7	25.2	19.7	14.1	32.2	2.5	32.2	32.2	30.2	24.7	19.2	13.6
	72	40.3	2.4	32.1	25.9	19.7	13.5	-	-	38.2	2.7	31.8	25.6	19.4	13.2	-	-
1250	67	37.9	2.4	37.9	32.3	26.1	19.9	13.7	-	35.2	2.7	35.2	31.9	25.7	19.5	13.3	-
	62	33.9	2.4	33.9	33.9	30.2	23.9	17.7	11.5	31.8	2.6	31.8	31.8	29.9	23.7	17.5	11.3
	57	34.8	2.4	34.8	34.8	31.5	25.3	19.1	12.9	33.4	2.6	33.4	33.4	31.7	25.5	19.3	13.1
			95°F							105°F							
	750	77	35.9	2.6	16.8	13.3	9.7	-	-	-	33.9	3.0	16.1	12.6	9.0	-	-
72		32.7	2.6	21.4	17.8	14.3	10.7	-	-	30.7	3.0	20.6	17.0	13.5	9.9	-	-
67		29.5	2.6	25.9	22.4	18.8	15.2	11.7	-	27.6	2.9	25.0	21.5	17.9	14.3	10.8	-
62		26.9	2.5	26.9	25.9	22.3	18.7	15.2	11.6	25.4	2.9	25.4	24.9	21.5	17.9	14.3	10.8
57		29.0	2.5	29.0	27.4	23.8	20.2	16.7	13.1	27.1	2.9	27.1	25.8	22.2	18.7	15.1	11.5
875	77	36.6	2.7	19.4	14.7	10.5	-	-	-	34.3	3.0	19.1	13.9	9.7	-	-	-
	72	33.3	2.7	23.8	19.6	15.4	11.2	-	-	31.1	3.0	22.9	18.7	14.5	10.2	-	-
	67	30.1	2.7	28.3	24.5	20.3	16.1	11.9	-	27.9	3.0	26.6	23.5	19.2	15.0	10.8	-
	62	27.4	2.6	27.4	26.9	24.1	19.9	15.7	11.4	25.7	2.9	25.7	25.5	23.1	18.9	14.7	10.4
	57	29.5	2.6	29.5	28.7	25.7	21.5	17.3	13.0	27.4	2.9	27.4	26.8	23.9	19.7	15.5	11.2
1000	77	37.3	2.8	21.9	16.1	11.3	-	-	-	34.7	3.1	22.1	15.2	10.4	-	-	-
	72	33.9	2.8	26.2	21.4	16.5	11.6	-	-	31.5	3.1	25.2	20.3	15.5	10.6	-	-
	67	30.6	2.8	30.6	26.6	21.8	16.9	12.0	-	28.3	3.1	28.3	25.4	20.6	15.7	10.9	-
	62	27.9	2.7	27.9	27.9	25.8	21.0	16.1	11.3	26.0	3.0	26.0	26.0	24.7	19.8	15.0	10.1
	57	30.1	2.7	30.1	30.1	27.6	22.7	17.8	13.0	27.7	3.0	27.7	27.7	25.5	20.7	15.8	11.0
1125	72	35.0	2.9	28.9	23.4	17.8	12.3	-	-	32.7	3.2	27.8	22.3	16.8	11.2	-	-
	67	31.6	2.9	31.6	29.1	23.5	18.0	12.4	-	29.4	3.2	29.4	27.7	22.3	16.8	11.3	-
	62	28.8	2.8	28.8	28.8	27.8	22.2	16.7	11.1	27.1	3.1	27.1	27.1	26.4	20.9	15.3	9.8
	57	31.0	2.8	31.0	31.0	29.8	24.2	18.7	13.2	28.8	3.1	28.8	28.8	27.7	22.2	16.6	11.1
	72	36.1	3.0	31.6	25.4	19.2	13.0	-	-	34.0	3.3	30.5	24.3	18.1	11.9	-	-
1250	67	32.5	3.0	32.5	31.5	25.3	19.1	12.8	-	30.5	3.3	30.5	30.0	24.1	17.9	11.7	-
	62	29.7	2.9	29.7	29.7	29.7	23.5	17.2	11.0	28.1	3.2	28.1	28.1	28.1	21.9	15.7	9.5
	57	32.0	2.9	32.0	32.0	32.0	25.7	19.5	13.3	29.9	3.2	29.9	29.9	29.9	23.7	17.4	11.2

TABLE 4: COOLING CAPACITIES - 2-1/2 TON (BHP030) (Continued)

Air on Evaporator Coil		Temperature of Air on Condenser Coil															
CFM	WB (°F)	Total Capacity ¹ (MBh)	Total Input (kW) ²	Sensible Capacity (MBh)						Total Capacity ¹ (MBh)	Total Input (kW) ²	Sensible Capacity (MBh)					
				Return Dry Bulb (°F)								Return Dry Bulb (°F)					
				90	85	80	75	70	65			90	85	80	75	70	65
				115°F						125°F							
750	77	31.9	3.3	15.4	11.9	8.3	-	-	-	29.8	3.6	14.7	11.1	7.6	-	-	-
	72	28.7	3.3	19.8	16.2	12.7	9.1	-	-	26.8	3.6	19.0	15.4	11.9	8.3	-	-
	67	25.6	3.3	24.1	20.6	17.0	13.5	9.9	-	23.7	3.6	23.3	19.7	16.1	12.6	9.0	-
	62	23.9	3.2	23.9	23.9	20.6	17.1	13.5	9.9	22.4	3.5	22.4	22.4	19.8	16.2	12.7	9.1
	57	25.1	3.2	25.1	24.2	20.7	17.1	13.5	10.0	23.2	3.6	23.2	22.6	19.1	15.5	12.0	8.4
875	77	32.1	3.4	18.9	13.1	8.9	-	-	-	29.8	3.7	18.7	12.3	8.1	-	-	-
	72	28.9	3.3	22.0	17.7	13.5	9.3	-	-	26.7	3.7	21.0	16.8	12.6	8.4	-	-
	67	25.8	3.3	25.0	22.4	18.2	14.0	9.8	-	23.6	3.6	23.4	21.4	17.2	13.0	8.8	-
	62	24.0	3.3	24.0	24.0	22.1	17.9	13.7	9.4	22.3	3.6	22.3	22.3	21.1	16.9	12.6	8.4
	57	25.3	3.3	25.3	24.8	22.1	17.9	13.7	9.5	23.1	3.7	23.1	22.9	20.3	16.1	11.9	7.7
1000	77	32.2	3.4	22.4	14.3	9.4	-	-	-	29.7	3.7	22.6	13.4	8.5	-	-	-
	72	29.1	3.4	24.1	19.3	14.4	9.6	-	-	26.6	3.7	23.1	18.2	13.4	8.5	-	-
	67	25.9	3.4	25.9	24.3	19.4	14.5	9.7	-	23.6	3.7	23.6	23.1	18.2	13.4	8.5	-
	62	24.2	3.3	24.2	24.2	23.5	18.7	13.8	8.9	22.3	3.7	22.3	22.3	22.3	17.5	12.6	7.8
	57	25.4	3.4	25.4	25.4	23.5	18.7	13.8	9.0	23.1	3.7	23.1	23.1	21.5	16.7	11.8	6.9
1125	72	30.5	3.5	26.8	21.3	15.7	10.2	-	-	28.2	3.8	25.7	20.2	14.7	9.1	-	-
	67	27.2	3.5	27.2	26.3	21.1	15.6	10.1	-	25.0	3.8	25.0	25.0	20.0	14.4	8.9	-
	62	25.3	3.4	25.3	25.3	25.0	19.5	14.0	8.4	23.6	3.8	23.6	23.6	23.6	18.1	12.6	7.0
	57	26.6	3.5	26.6	26.6	25.7	20.1	14.6	9.0	24.5	3.9	24.5	24.5	23.6	18.1	12.5	7.0
	1250	72	31.9	3.6	29.4	23.2	17.0	10.8	-	-	29.8	3.9	28.4	22.2	15.9	9.7	-
67		28.4	3.6	28.4	28.4	22.9	16.7	10.5	-	26.4	3.9	26.4	26.4	21.7	15.5	9.3	-
62		26.5	3.5	26.5	26.5	26.5	20.3	14.1	7.9	25.0	3.9	25.0	25.0	25.0	18.7	12.5	6.3
57		27.9	3.6	27.9	27.9	27.8	21.6	15.4	9.1	25.9	4.0	25.9	25.9	25.7	19.5	13.3	7.1

1. These capacities are Net Capacities.
2. These ratings include the compressor, condenser fan and supply air blower motors.

TABLE 5: COOLING CAPACITIES - 3 TON (BHP036)

Air on Evaporator Coil		Temperature of Air on Condenser Coil																
CFM	WB (°F)	Total Capacity ¹ (MBh)	Total Input (kW) ²	Sensible Capacity (MBh)						Total Capacity ¹ (MBh)	Total Input (kW) ²	Sensible Capacity (MBh)						
				Return Dry Bulb (°F)								Return Dry Bulb (°F)						
				90	85	80	75	70	65			90	85	80	75	70	65	
		75°F								85°F								
900	77	45.5	2.5	19.8	15.5	11.3	-	-	-	43.0	2.8	20.2	16.0	11.7	-	-	-	
	72	41.8	2.4	26.8	22.6	18.3	14.0	-	-	39.5	2.7	26.5	22.2	17.9	13.6	-	-	
	67	38.2	2.3	33.9	29.6	25.3	21.0	16.7	-	35.9	2.6	32.7	28.4	24.1	19.9	15.6	-	
	62	34.9	2.2	34.9	34.9	30.1	25.8	21.6	17.3	33.1	2.6	33.1	33.1	29.1	24.9	20.6	16.3	
	57	34.4	2.2	34.4	34.4	30.8	26.6	22.3	18.0	32.9	2.6	32.9	32.9	29.5	25.3	21.0	16.7	
1050	77	47.1	2.6	23.1	17.5	12.4	-	-	-	44.3	2.9	24.0	17.8	12.8	-	-	-	
	72	43.3	2.5	30.2	25.2	20.1	15.1	-	-	40.7	2.8	29.7	24.7	19.6	14.5	-	-	
	67	39.5	2.4	37.4	32.9	27.9	22.8	17.7	-	37.0	2.7	35.4	31.5	26.4	21.4	16.3	-	
	62	36.1	2.3	36.1	36.1	33.2	28.1	23.0	18.0	34.1	2.6	34.1	34.1	31.9	26.9	21.8	16.7	
	57	35.6	2.3	35.6	35.6	33.9	28.9	23.8	18.8	33.9	2.6	33.9	33.9	32.3	27.3	22.2	17.2	
1200	77	48.7	2.7	26.4	19.4	13.6	-	-	-	45.6	3.0	27.8	19.7	13.9	-	-	-	
	72	44.8	2.6	33.6	27.8	22.0	16.1	-	-	41.9	2.9	33.0	27.1	21.3	15.5	-	-	
	67	40.9	2.5	40.9	36.2	30.4	24.6	18.7	-	38.1	2.8	38.1	34.5	28.7	22.9	17.0	-	
	62	37.4	2.4	37.4	37.4	36.2	30.4	24.5	18.7	35.1	2.7	35.1	35.1	34.7	28.8	23.0	17.2	
	57	36.8	2.4	36.8	36.8	37.0	31.2	25.4	19.6	34.9	2.7	34.9	34.9	35.1	29.3	23.5	17.7	
1350	72	45.1	2.7	36.4	29.7	23.1	16.4	-	-	42.3	3.0	35.8	29.2	22.5	15.9	-	-	
	67	41.2	2.6	41.2	38.9	31.9	25.3	18.7	-	38.5	2.9	38.5	36.7	30.4	23.7	17.1	-	
	62	37.7	2.5	37.7	37.7	37.1	30.4	23.8	17.2	35.5	2.8	35.5	35.5	35.2	28.6	22.0	15.3	
	57	37.1	2.5	37.1	37.1	37.2	30.6	23.9	17.3	35.2	2.8	35.2	35.2	35.4	28.7	22.1	15.4	
	72	45.5	2.9	39.1	31.7	24.2	16.7	-	-	42.7	3.1	38.7	31.2	23.8	16.3	-	-	
1500	67	41.5	2.7	41.5	41.5	33.5	26.0	18.6	-	38.9	3.0	38.9	38.9	32.0	24.6	17.1	-	
	62	38.0	2.7	38.0	38.0	38.0	30.5	23.1	15.6	35.8	3.0	35.8	35.8	35.8	28.4	20.9	13.5	
	57	37.4	2.6	37.4	37.4	37.4	29.9	22.5	15.0	35.6	2.9	35.6	35.6	35.6	28.1	20.7	13.2	
			95°F								105°F							
	900	77	40.5	3.1	20.6	16.4	12.1	-	-	-	37.7	3.5	19.8	15.6	11.3	-	-	-
72		37.1	3.0	26.1	21.8	17.5	13.2	-	-	34.3	3.4	25.1	20.9	16.6	12.3	-	-	
67		33.7	3.0	31.5	27.2	23.0	18.7	14.4	-	31.0	3.3	29.9	26.1	21.9	17.6	13.3	-	
62		31.3	2.9	31.3	31.3	28.2	23.9	19.6	15.3	28.5	3.2	28.5	28.5	25.8	21.6	17.3	13.0	
57		31.4	2.9	31.4	31.4	28.3	24.0	19.7	15.4	29.3	3.3	29.3	29.3	26.5	22.2	17.9	13.7	
1050	77	41.5	3.2	24.9	18.2	13.2	-	-	-	38.6	3.6	24.7	17.4	12.2	-	-	-	
	72	38.0	3.1	29.2	24.1	19.1	14.0	-	-	35.1	3.5	28.1	23.0	18.0	12.9	-	-	
	67	34.5	3.1	33.5	30.0	25.0	19.9	14.9	-	31.7	3.4	31.2	28.7	23.7	18.6	13.6	-	
	62	32.1	3.0	32.1	32.1	30.7	25.6	20.6	15.5	29.1	3.3	29.1	29.1	28.0	22.9	17.9	12.8	
	57	32.2	3.0	32.2	32.2	30.8	25.7	20.6	15.6	30.0	3.3	30.0	30.0	28.7	23.7	18.6	13.6	
1200	77	42.6	3.3	29.2	20.1	14.2	-	-	-	39.4	3.7	29.6	19.2	13.2	-	-	-	
	72	39.0	3.2	32.3	26.5	20.6	14.8	-	-	35.9	3.6	31.0	25.2	19.3	13.5	-	-	
	67	35.4	3.2	35.4	32.8	27.0	21.2	15.3	-	32.5	3.5	32.5	31.2	25.5	19.7	13.8	-	
	62	32.9	3.1	32.9	32.9	33.1	27.3	21.5	15.7	29.8	3.4	29.8	29.8	30.2	24.3	18.5	12.7	
	57	33.0	3.1	33.0	33.0	33.2	27.4	21.6	15.8	30.7	3.4	30.7	30.7	30.9	25.1	19.3	13.4	
1350	72	39.4	3.3	35.3	28.6	22.0	15.3	-	-	36.4	3.7	33.5	27.2	20.5	13.9	-	-	
	67	35.8	3.2	35.8	34.5	28.8	22.2	15.5	-	32.8	3.6	32.8	32.2	27.1	20.4	13.8	-	
	62	33.3	3.1	33.3	33.3	33.4	26.8	20.1	13.5	30.2	3.5	30.2	30.2	30.3	23.7	17.1	10.4	
	57	33.4	3.2	33.4	33.4	33.5	26.9	20.2	13.6	31.1	3.5	31.1	31.1	31.2	24.5	17.9	11.3	
	72	39.9	3.4	38.2	30.8	23.3	15.9	-	-	36.8	3.8	36.0	29.2	21.7	14.3	-	-	
1500	67	36.2	3.3	36.2	36.2	30.6	23.1	15.7	-	33.2	3.7	33.2	33.2	28.7	21.2	13.8	-	
	62	33.7	3.2	33.7	33.7	33.7	26.2	18.8	11.3	30.5	3.6	30.5	30.5	30.5	23.1	15.6	8.2	
	57	33.8	3.3	33.8	33.8	33.8	26.3	18.9	11.4	31.4	3.6	31.4	31.4	31.4	24.0	16.5	9.1	

TABLE 5: COOLING CAPACITIES - 3 TON (BHP036) (Continued)

Air on Evaporator Coil		Temperature of Air on Condenser Coil															
CFM	WB (°F)	Total Capacity ¹ (MBh)	Total Input (kW) ²	Sensible Capacity (MBh)						Total Capacity ¹ (MBh)	Total Input (kW) ²	Sensible Capacity (MBh)					
				Return Dry Bulb (°F)								Return Dry Bulb (°F)					
				90	85	80	75	70	65			90	85	80	75	70	65
				115°F						125°F							
900	77	34.9	3.9	19.0	14.8	10.5	-	-	-	32.0	4.3	18.2	14.0	9.7	-	-	-
	72	31.6	3.8	24.2	19.9	15.6	11.3	-	-	28.9	4.2	23.2	19.0	14.7	10.4	-	-
	67	28.3	3.7	28.3	25.0	20.8	16.5	12.2	-	25.7	4.0	25.7	23.9	19.7	15.4	11.1	-
	62	25.7	3.6	25.7	25.7	23.5	19.2	14.9	10.7	22.8	4.0	22.8	22.8	21.2	16.9	12.6	8.3
	57	27.3	3.6	27.3	27.3	24.7	20.5	16.2	11.9	25.2	4.0	25.2	25.2	23.0	18.7	14.4	10.2
1050	77	35.6	4.0	24.5	16.5	11.3	-	-	-	32.6	4.4	24.3	15.7	10.4	-	-	-
	72	32.3	3.9	27.0	21.9	16.8	11.8	-	-	29.4	4.3	25.8	20.8	15.7	10.7	-	-
	67	28.9	3.8	28.9	27.3	22.4	17.3	12.3	-	26.1	4.1	26.1	25.9	21.1	16.0	11.0	-
	62	26.2	3.7	26.2	26.2	25.3	20.3	15.2	10.2	23.2	4.1	23.2	23.2	22.7	17.6	12.6	7.5
	57	27.9	3.7	27.9	27.9	26.7	21.6	16.6	11.5	25.7	4.1	25.7	25.7	24.6	19.6	14.5	9.5
1200	77	36.3	4.1	30.0	18.3	12.1	-	-	-	33.2	4.5	30.4	17.4	11.1	-	-	-
	72	32.9	4.0	29.7	23.9	18.1	12.2	-	-	29.9	4.4	28.5	22.6	16.8	11.0	-	-
	67	29.5	3.8	29.5	29.5	24.0	18.2	12.4	-	26.6	4.2	26.6	26.6	22.5	16.7	10.9	-
	62	26.7	3.8	26.7	26.7	27.2	21.3	15.5	9.7	23.6	4.2	23.6	23.6	23.6	18.4	12.5	6.7
	57	28.4	3.8	28.4	28.4	28.6	22.8	17.0	11.1	26.1	4.2	26.1	26.1	26.1	20.5	14.6	8.8
1350	72	33.3	4.1	31.7	25.7	19.1	12.5	-	-	30.2	4.5	29.9	24.3	17.7	11.0	-	-
	67	29.9	3.9	29.9	29.9	25.4	18.7	12.1	-	26.9	4.3	26.9	26.9	23.7	17.0	10.4	-
	62	27.0	3.9	27.0	27.0	27.3	20.6	14.0	7.3	23.9	4.3	23.9	23.9	23.9	17.6	10.9	4.3
	57	28.8	3.9	28.8	28.8	28.9	22.2	15.6	8.9	26.5	4.3	26.5	26.5	26.5	19.9	13.3	6.6
1500	72	33.7	4.2	33.7	27.6	20.1	12.7	-	-	30.6	4.6	30.6	26.0	18.5	11.1	-	-
	67	30.2	4.0	30.2	30.2	26.8	19.3	11.9	-	27.2	4.4	27.2	27.2	24.8	17.4	9.9	-
	62	27.4	4.0	27.4	27.4	27.4	19.9	12.5	5.0	24.2	4.4	24.2	24.2	24.2	16.8	9.3	1.9
	57	29.1	4.0	29.1	29.1	29.1	21.7	14.2	6.8	26.8	4.4	26.8	26.8	26.8	19.3	11.9	4.4

1. These capacities are Net Capacities.
2. These ratings include the compressor, condenser fan and supply air blower motors.

TABLE 6: COOLING CAPACITIES - 3-1/2 TON (BHP042)

Air on Evaporator Coil		Temperature of Air on Condenser Coil																
CFM	WB (°F)	Total Capacity ¹ (MBh)	Total Input (kW) ²	Sensible Capacity (MBh)						Total Capacity ¹ (MBh)	Total Input (kW) ²	Sensible Capacity (MBh)						
				Return Dry Bulb (°F)								Return Dry Bulb (°F)						
				90	85	80	75	70	65			90	85	80	75	70	65	
		75°F								85°F								
1050	77	54.4	2.9	25.2	20.2	15.2	-	-	-	50.7	3.2	24.5	19.5	14.5	-	-	-	
	72	49.7	2.9	32.3	27.3	22.3	17.3	-	-	46.6	3.2	31.4	26.4	21.4	16.4	-	-	
	67	45.0	2.8	39.4	34.5	29.5	24.5	19.5	-	42.4	3.1	38.3	33.3	28.3	23.3	18.3	-	
	62	40.6	2.7	40.6	40.6	35.9	30.9	25.9	20.9	38.6	3.0	38.6	38.6	34.6	29.6	24.6	19.6	
	57	40.7	2.7	40.7	40.7	38.0	33.0	28.0	23.0	38.8	3.0	38.8	38.8	35.8	30.8	25.8	20.9	
1225	77	55.5	3.1	28.3	22.2	16.3	-	-	-	51.6	3.3	28.5	21.5	15.6	-	-	-	
	72	50.7	3.0	35.8	29.9	24.0	18.1	-	-	47.4	3.3	34.8	28.9	23.0	17.1	-	-	
	67	46.0	2.9	43.2	37.5	31.6	25.7	19.8	-	43.2	3.2	41.1	36.3	30.4	24.5	18.7	-	
	62	41.4	2.8	41.4	41.4	38.5	32.6	26.7	20.8	39.3	3.1	39.3	39.3	37.2	31.3	25.4	19.5	
	57	41.5	2.8	41.5	41.5	40.8	34.9	29.0	23.1	39.5	3.1	39.5	39.5	38.5	32.6	26.7	20.8	
1400	77	56.6	3.2	31.5	24.2	17.4	-	-	-	52.5	3.4	32.5	23.5	16.7	-	-	-	
	72	51.7	3.1	39.2	32.4	25.6	18.8	-	-	48.2	3.4	38.2	31.4	24.6	17.8	-	-	
	67	46.9	3.0	46.9	40.6	33.8	27.0	20.1	-	43.9	3.3	43.9	39.4	32.6	25.8	19.0	-	
	62	42.2	2.9	42.2	42.2	41.1	34.3	27.5	20.7	40.0	3.2	40.0	40.0	39.8	33.0	26.2	19.4	
	57	42.3	2.9	42.3	42.3	43.5	36.7	29.9	23.1	40.2	3.2	40.2	40.2	41.2	34.4	27.6	20.8	
1575	72	51.9	3.3	42.8	35.0	27.3	19.5	-	-	48.4	3.6	41.8	34.0	26.3	18.5	-	-	
	67	47.1	3.2	47.1	43.9	36.0	28.3	20.5	-	44.1	3.5	44.1	41.8	34.7	27.0	19.2	-	
	62	42.4	3.1	42.4	42.4	41.9	34.1	26.4	18.6	40.2	3.4	40.2	40.2	40.1	32.3	24.6	16.8	
	57	42.5	3.1	42.5	42.5	43.1	35.4	27.6	19.9	40.3	3.4	40.3	40.3	40.8	33.1	25.3	17.6	
	72	52.2	3.6	46.4	37.7	29.0	20.3	-	-	48.6	3.8	45.3	36.6	27.9	19.2	-	-	
1750	67	47.3	3.5	47.3	47.3	38.2	29.6	20.9	-	44.3	3.7	44.3	44.3	36.9	28.2	19.5	-	
	62	42.6	3.4	42.6	42.6	42.6	33.9	25.2	16.5	40.3	3.6	40.3	40.3	40.3	31.6	22.9	14.2	
	57	42.7	3.3	42.7	42.7	42.7	34.0	25.3	16.6	40.5	3.6	40.5	40.5	40.5	31.8	23.1	14.4	
			95°F								105°F							
	1050	77	47.1	3.5	23.8	18.8	13.8	-	-	-	45.0	3.9	22.7	17.7	12.7	-	-	-
72		43.4	3.5	30.5	25.5	20.5	15.5	-	-	41.0	3.9	29.2	24.3	19.3	14.3	-	-	
67		39.8	3.4	37.1	32.2	27.2	22.2	17.2	-	36.9	3.8	35.6	30.8	25.8	20.8	15.8	-	
62		36.7	3.3	36.7	36.7	33.3	28.3	23.3	18.3	34.4	3.7	34.4	34.4	30.9	25.9	20.9	15.9	
57		36.9	3.3	36.9	36.9	33.6	28.7	23.7	18.7	34.8	3.7	34.8	34.8	31.0	26.0	21.1	16.1	
1225	77	47.8	3.6	28.7	20.8	14.9	-	-	-	45.5	4.0	28.4	19.8	13.8	-	-	-	
	72	44.1	3.6	33.9	28.0	22.1	16.2	-	-	41.5	4.0	32.6	26.7	20.8	14.9	-	-	
	67	40.4	3.5	39.1	35.2	29.3	23.4	17.5	-	37.4	3.9	36.8	33.6	27.9	22.0	16.1	-	
	62	37.2	3.4	37.2	37.2	35.9	30.0	24.1	18.2	34.9	3.8	34.9	34.9	33.4	27.5	21.6	15.7	
	57	37.4	3.4	37.4	37.4	36.3	30.4	24.5	18.6	35.2	3.8	35.2	35.2	33.5	27.6	21.7	15.8	
1400	77	48.5	3.7	33.5	22.7	15.9	-	-	-	46.1	4.1	34.1	21.9	14.8	-	-	-	
	72	44.8	3.7	37.3	30.5	23.7	16.9	-	-	42.0	4.0	36.0	29.2	22.4	15.6	-	-	
	67	41.0	3.7	41.0	38.2	31.4	24.6	17.8	-	37.9	4.0	37.9	36.5	30.0	23.1	16.3	-	
	62	37.8	3.5	37.8	37.8	38.5	31.6	24.8	18.0	35.3	3.9	35.3	35.3	35.9	29.1	22.3	15.5	
	57	38.0	3.5	38.0	38.0	38.9	32.1	25.3	18.5	35.7	3.9	35.7	35.7	36.0	29.2	22.4	15.6	
1575	72	44.9	3.8	40.7	33.0	25.2	17.5	-	-	42.7	4.2	39.5	31.7	24.0	16.2	-	-	
	67	41.1	3.8	41.1	39.7	33.5	25.7	18.0	-	38.6	4.2	38.6	37.8	32.1	24.3	16.6	-	
	62	37.9	3.7	37.9	37.9	38.2	30.5	22.7	15.0	35.9	4.1	35.9	35.9	36.2	28.5	20.7	13.0	
	57	38.1	3.7	38.1	38.1	38.6	30.8	23.1	15.3	36.3	4.1	36.3	36.3	36.5	28.7	21.0	13.2	
	72	45.1	3.9	44.2	35.5	26.8	18.1	-	-	43.5	4.4	42.9	34.2	25.5	16.8	-	-	
1750	67	41.3	3.9	41.3	41.3	35.6	26.9	18.2	-	39.2	4.4	39.2	39.2	34.2	25.5	16.8	-	
	62	38.0	3.8	38.0	38.0	38.0	29.3	20.7	12.0	36.6	4.3	36.6	36.6	36.6	27.9	19.2	10.5	
	57	38.3	3.8	38.3	38.3	38.3	29.6	20.9	12.2	37.0	4.3	37.0	37.0	37.0	28.3	19.6	10.9	

TABLE 6: COOLING CAPACITIES - 3-1/2 TON (BHP042) (Continued)

Air on Evaporator Coil		Temperature of Air on Condenser Coil																	
CFM	WB (°F)	Total Capacity ¹ (MBh)	Total Input (kW) ²	Sensible Capacity (MBh)						Total Capacity ¹ (MBh)	Total Input (kW) ²	Sensible Capacity (MBh)							
				Return Dry Bulb (°F)								Return Dry Bulb (°F)							
				90	85	80	75	70	65			90	85	80	75	70	65		
		115°F												125°F					
1050	77	42.8	4.3	21.7	16.7	11.7	-	-	-	40.7	4.7	20.6	15.6	10.7	-	-	-		
	72	38.5	4.3	28.0	23.0	18.1	13.1	-	-	36.0	4.6	26.8	21.8	16.8	11.9	-	-		
	67	34.1	4.2	34.1	29.4	24.4	19.4	14.4	-	31.2	4.6	32.6	28.0	23.0	18.1	13.1	-		
	62	32.2	4.1	32.2	32.2	28.5	23.5	18.6	13.6	30.0	4.5	30.0	30.0	26.2	21.2	16.2	11.2		
	57	32.7	4.1	32.7	32.7	28.4	23.4	18.4	13.5	30.6	4.5	30.6	30.6	25.8	20.8	15.8	10.8		
1225	77	43.2	4.4	28.1	18.8	12.7	-	-	-	41.0	4.8	27.9	17.9	11.6	-	-	-		
	72	38.8	4.3	31.4	25.5	19.6	13.7	-	-	36.2	4.7	30.1	24.2	18.3	12.4	-	-		
	67	34.4	4.3	34.4	32.1	26.5	20.6	14.7	-	31.5	4.7	32.1	30.5	25.1	19.2	13.3	-		
	62	32.5	4.2	32.5	32.5	30.9	25.0	19.1	13.2	30.2	4.6	30.2	30.2	28.5	22.6	16.7	10.8		
	57	33.0	4.2	33.0	33.0	30.8	24.9	19.0	13.1	30.8	4.6	30.8	30.8	28.1	22.2	16.3	10.4		
1400	77	43.7	4.5	34.6	21.0	13.7	-	-	-	41.3	4.9	35.1	20.1	12.5	-	-	-		
	72	39.2	4.4	34.7	27.9	21.1	14.3	-	-	36.5	4.8	33.4	26.6	19.8	13.0	-	-		
	67	34.8	4.4	34.8	34.8	28.5	21.7	14.9	-	31.7	4.7	31.7	33.1	27.1	20.3	13.5	-		
	62	32.9	4.3	32.9	32.9	33.3	26.5	19.7	12.9	30.4	4.7	30.4	30.4	30.8	23.9	17.1	10.3		
	57	33.4	4.3	33.4	33.4	33.2	26.4	19.6	12.8	31.1	4.7	31.1	31.1	30.3	23.5	16.7	9.9		
1575	72	40.6	4.6	38.2	30.4	22.7	14.9	-	-	38.4	5.1	36.9	29.1	21.4	13.6	-	-		
	67	36.0	4.6	36.0	36.0	30.7	22.9	15.2	-	33.4	5.0	33.4	34.1	29.2	21.5	13.7	-		
	62	34.0	4.5	34.0	34.0	34.2	26.5	18.7	11.0	32.0	4.9	32.0	32.0	32.2	24.4	16.7	8.9		
	57	34.5	4.5	34.5	34.5	34.4	26.7	18.9	11.2	32.7	4.9	32.7	32.7	32.3	24.6	16.8	9.1		
1750	72	41.9	4.9	41.6	33.0	24.3	15.6	-	-	40.3	5.3	40.4	31.7	23.0	14.3	-	-		
	67	37.1	4.8	37.1	37.1	32.8	24.1	15.4	-	35.1	5.2	35.1	35.1	31.4	22.7	14.0	-		
	62	35.1	4.7	35.1	35.1	35.1	26.4	17.7	9.0	33.6	5.2	33.6	33.6	33.6	24.9	16.2	7.5		
	57	35.6	4.7	35.6	35.6	35.6	26.9	18.2	9.6	34.3	5.2	34.3	34.3	34.3	25.6	16.9	8.2		

1. These capacities are Net Capacities.
2. These ratings include the compressor, condenser fan and supply air blower motors.

TABLE 7: COOLING CAPACITIES - 4 TON (BHP048)

Air on Evaporator Coil		Temperature of Air on Condenser Coil															
CFM	WB (°F)	Total Capacity ¹ (MBh)	Total Input (kW) ²	Sensible Capacity (MBh)						Total Capacity ¹ (MBh)	Total Input (kW) ²	Sensible Capacity (MBh)					
				Return Dry Bulb (°F)								Return Dry Bulb (°F)					
				90	85	80	75	70	65			90	85	80	75	70	65
		75°F									85°F						
1200	77	55.3	3.4	26.7	21.0	15.2	-	-	-	54.6	3.7	26.6	20.9	15.2	-	-	-
	72	52.5	3.3	35.6	29.9	24.2	18.5	-	-	51.0	3.6	35.0	29.3	23.5	17.8	-	-
	67	49.6	3.1	44.5	38.8	33.1	27.4	21.7	-	47.4	3.5	43.3	37.6	31.9	26.2	20.5	-
	62	44.6	3.0	44.6	44.6	39.4	33.7	28.0	22.3	43.0	3.4	43.0	43.0	38.3	32.6	26.9	21.2
	57	46.7	3.0	46.7	46.7	41.2	35.5	29.8	24.1	45.3	3.4	45.3	45.3	39.7	34.0	28.3	22.6
1400	77	57.2	3.6	30.9	23.4	16.6	-	-	-	56.0	3.9	31.5	23.2	16.4	-	-	-
	72	54.2	3.4	39.8	33.1	26.3	19.6	-	-	52.3	3.7	39.0	32.3	25.5	18.8	-	-
	67	51.3	3.3	48.7	42.8	36.1	29.3	22.6	-	48.6	3.6	46.5	41.3	34.6	27.9	21.1	-
	62	46.1	3.1	46.1	46.1	42.9	36.2	29.4	22.7	44.1	3.5	44.1	44.1	41.5	34.8	28.1	21.3
	57	48.2	3.2	48.2	48.3	44.9	38.1	31.4	24.7	46.4	3.5	46.4	46.4	43.0	36.3	29.5	22.8
1600	77	59.1	3.7	35.2	25.8	18.0	-	-	-	57.3	4.0	36.4	25.5	17.7	-	-	-
	72	56.0	3.6	44.1	36.3	28.5	20.7	-	-	53.5	3.9	43.0	35.3	27.5	19.7	-	-
	67	53.0	3.4	53.0	46.8	39.0	31.3	23.5	-	49.7	3.8	49.7	45.1	37.3	29.5	21.7	-
	62	47.6	3.3	47.6	47.6	46.4	38.7	30.9	23.1	45.1	3.7	45.1	45.1	44.7	37.0	29.2	21.4
	57	49.8	3.3	49.8	49.8	48.6	40.8	33.0	25.2	47.5	3.7	47.5	47.5	46.3	38.6	30.8	23.0
1800	72	54.6	3.7	46.1	37.3	28.4	19.5	-	-	52.8	4.0	45.5	36.6	27.8	18.9	-	-
	67	51.6	3.5	51.6	48.3	38.9	30.0	21.2	-	49.0	3.9	49.0	46.5	37.7	28.8	20.0	-
	62	46.3	3.4	46.3	46.3	45.8	36.9	28.1	19.2	44.5	3.8	44.5	44.5	44.3	35.4	26.6	17.7
	57	48.5	3.4	48.5	48.5	47.9	39.0	30.2	21.3	46.9	3.8	46.9	46.9	46.3	37.4	28.6	19.7
	72	53.1	3.8	48.1	38.2	28.3	18.3	-	-	52.0	4.1	47.9	38.0	28.1	18.1	-	-
2000	67	50.3	3.6	50.3	49.7	38.7	28.8	18.9	-	48.3	4.0	48.3	48.0	38.1	28.1	18.2	-
	62	45.1	3.5	45.1	45.1	45.1	35.2	25.3	15.3	43.8	3.9	43.8	43.8	43.8	33.9	24.0	14.0
	57	47.3	3.6	47.3	47.3	47.3	37.3	27.4	17.4	46.2	3.9	46.2	46.2	46.2	36.3	26.3	16.4
			95°F									105°F					
	1200	77	54.0	4.0	26.5	20.8	15.1	-	-	-	51.4	4.4	25.5	19.8	14.1	-	-
72		49.6	3.9	34.3	28.6	22.9	17.2	-	-	47.0	4.4	33.3	27.6	21.9	16.2	-	-
67		45.2	3.8	42.2	36.5	30.8	25.1	19.4	-	42.6	4.3	41.0	35.3	29.6	23.9	18.2	-
62		41.4	3.8	41.4	41.4	37.3	31.6	25.9	20.2	38.6	4.2	38.6	38.6	36.2	30.5	24.8	19.1
57		44.0	3.7	44.0	43.9	38.2	32.5	26.8	21.1	41.7	4.1	41.7	41.6	35.9	30.2	24.5	18.8
1400	77	54.8	4.2	32.0	23.0	16.2	-	-	-	52.0	4.6	31.9	22.1	15.3	-	-	-
	72	50.3	4.1	38.2	31.4	24.7	18.0	-	-	47.5	4.5	37.1	30.4	23.6	16.9	-	-
	67	45.8	4.0	44.3	39.9	33.1	26.4	19.7	-	43.1	4.5	42.3	38.7	32.0	25.3	18.5	-
	62	42.1	3.9	42.1	42.1	40.2	33.4	26.7	19.9	39.0	4.4	39.0	39.0	39.1	32.3	25.6	18.8
	57	44.6	3.9	44.6	44.6	41.2	34.4	27.7	20.9	42.1	4.3	42.1	42.1	38.8	32.1	25.3	18.6
1600	77	55.5	4.3	37.5	25.2	17.4	-	-	-	52.6	4.8	38.3	24.4	16.4	-	-	-
	72	51.0	4.3	42.0	34.2	26.5	18.7	-	-	48.1	4.7	40.9	33.2	25.4	17.6	-	-
	67	46.5	4.2	46.5	43.3	35.5	27.7	20.0	-	43.6	4.6	43.6	42.0	34.4	26.6	18.8	-
	62	42.7	4.1	42.7	42.7	43.1	35.3	27.5	19.7	39.5	4.5	39.5	39.5	42.0	34.2	26.4	18.6
	57	45.3	4.1	45.3	45.3	44.1	36.3	28.6	20.8	42.6	4.5	42.6	42.6	41.7	33.9	26.1	18.4
1800	72	50.9	4.3	44.9	36.0	27.2	18.3	-	-	47.9	4.8	43.6	34.9	26.0	17.2	-	-
	67	46.4	4.3	46.4	44.8	36.5	27.6	18.8	-	43.5	4.7	43.5	42.7	35.2	26.4	17.5	-
	62	42.6	4.2	42.6	42.6	42.8	33.9	25.1	16.2	39.4	4.6	39.4	39.4	40.6	31.8	22.9	14.1
	57	45.2	4.1	45.2	45.2	44.6	35.8	26.9	18.1	42.5	4.6	42.5	42.5	42.0	33.2	24.3	15.5
	72	50.8	4.4	47.8	37.8	27.9	17.9	-	-	47.8	4.9	46.3	36.6	26.7	16.7	-	-
2000	67	46.3	4.3	46.3	46.3	37.4	27.5	17.5	-	43.3	4.8	43.3	43.3	36.1	26.2	16.2	-
	62	42.5	4.3	42.5	42.5	42.5	32.6	22.6	12.7	39.3	4.7	39.3	39.3	39.3	29.3	19.4	9.5
	57	45.1	4.2	45.1	45.1	45.1	35.2	25.2	15.3	42.4	4.6	42.4	42.4	42.4	32.4	22.5	12.6

TABLE 7: COOLING CAPACITIES - 4 TON (BHP048) (Continued)

Air on Evaporator Coil		Temperature of Air on Condenser Coil																	
CFM	WB (°F)	Total Capacity ¹ (MBh)	Total Input (kW) ²	Sensible Capacity (MBh)						Total Capacity ¹ (MBh)	Total Input (kW) ²	Sensible Capacity (MBh)							
				Return Dry Bulb (°F)								Return Dry Bulb (°F)							
				90	85	80	75	70	65			90	85	80	75	70	65		
		115°F												125°F					
1200	77	48.8	4.9	24.6	18.9	13.2	-	-	-	46.2	5.4	23.7	18.0	12.3	-	-	-		
	72	44.4	4.8	32.3	26.6	20.9	15.2	-	-	41.8	5.3	31.3	25.6	19.9	14.1	-	-		
	67	40.0	4.7	39.9	34.2	28.5	22.8	17.1	-	37.4	5.2	37.4	33.1	27.4	21.7	16.0	-		
	62	35.8	4.6	35.8	35.8	35.1	29.4	23.7	18.0	32.9	5.0	32.9	32.9	32.9	28.3	22.6	16.9		
	57	39.3	4.6	39.3	39.3	33.7	28.0	22.3	16.6	37.0	5.0	37.0	37.0	31.4	25.7	20.0	14.3		
1400	77	49.2	5.1	31.9	21.2	14.3	-	-	-	46.4	5.6	31.8	20.3	13.3	-	-	-		
	72	44.8	5.0	36.1	29.3	22.6	15.9	-	-	42.0	5.5	35.0	28.3	21.5	14.8	-	-		
	67	40.3	4.9	40.3	37.4	30.9	24.1	17.4	-	37.6	5.3	37.6	36.2	29.8	23.0	16.3	-		
	62	36.0	4.8	36.0	36.0	38.0	31.2	24.5	17.8	33.0	5.2	33.0	33.0	30.1	23.4	16.7			
	57	39.6	4.8	39.6	39.6	36.5	29.7	23.0	16.2	37.2	5.2	37.2	37.2	34.1	27.4	20.6	13.9		
1600	77	49.6	5.3	39.1	23.5	15.4	-	-	-	46.6	5.8	39.9	22.7	14.4	-	-	-		
	72	45.1	5.2	39.9	32.1	24.3	16.5	-	-	42.2	5.7	38.8	31.0	23.2	15.5	-	-		
	67	40.7	5.1	40.7	40.7	33.2	25.5	17.7	-	37.7	5.5	37.7	37.7	32.1	24.3	16.5	-		
	62	36.3	5.0	36.3	36.3	40.9	33.1	25.3	17.5	33.2	5.4	33.2	33.2	32.0	24.2	16.4			
	57	40.0	4.9	40.0	40.0	39.2	31.5	23.7	15.9	37.3	5.4	37.3	37.3	36.8	29.0	21.2	13.5		
1800	72	44.9	5.3	42.3	33.7	24.9	16.0	-	-	41.9	5.7	41.0	32.6	23.8	14.9	-	-		
	67	40.5	5.2	40.5	40.5	34.0	25.2	16.3	-	37.5	5.6	37.5	37.5	32.8	23.9	15.1	-		
	62	36.2	5.0	36.2	36.2	38.5	29.6	20.7	11.9	33.0	5.5	33.0	33.0	33.0	27.4	18.6	9.7		
	57	39.8	5.0	39.8	39.8	39.4	30.6	21.7	12.9	37.1	5.4	37.1	37.1	36.8	28.0	19.1	10.3		
	72	44.8	5.3	44.8	35.4	25.5	15.5	-	-	41.7	5.8	41.7	34.2	24.3	14.3	-	-		
2000	67	40.3	5.2	40.3	40.3	34.8	24.9	14.9	-	37.3	5.6	37.3	37.3	33.5	23.6	13.6	-		
	62	36.0	5.1	36.0	36.0	36.0	26.1	16.2	6.2	32.8	5.5	32.8	32.8	32.8	22.9	12.9	3.0		
	57	39.6	5.1	39.6	39.6	39.6	29.7	19.8	9.8	36.9	5.5	36.9	36.9	36.9	27.0	17.0	7.1		

1. These capacities are Net Capacities.
2. These ratings include the compressor, condenser fan and supply air blower motors.

TABLE 8: COOLING CAPACITIES - 5 TON (BHP060)

Air on Evaporator Coil		Temperature of Air on Condenser Coil															
CFM	WB (°F)	Total Capacity ¹ (MBh)	Total Input (kW) ²	Sensible Capacity (MBh)						Total Capacity ¹ (MBh)	Total Input (kW) ²	Sensible Capacity (MBh)					
				Return Dry Bulb (°F)								Return Dry Bulb (°F)					
				90	85	80	75	70	65			90	85	80	75	70	65
		75°F								85°F							
1500	77	70.1	3.9	39.2	32.1	24.9	-	-	-	69.9	4.7	38.4	31.2	24.1	-	-	-
	72	64.6	3.9	49.3	42.2	35.1	27.9	-	-	64.4	4.7	48.4	41.3	34.2	27.0	-	-
	67	59.1	4.0	59.5	52.3	45.2	38.1	30.9	-	58.8	4.6	58.5	51.4	44.2	37.1	30.0	-
	62	54.0	3.7	54.0	54.0	54.2	47.1	39.9	32.8	53.7	4.5	53.7	53.7	53.3	46.2	39.1	32.0
	57	54.2	3.5	54.2	54.2	54.2	47.0	39.9	32.8	53.4	4.3	53.4	53.4	53.4	46.3	39.2	32.0
1750	77	71.6	4.0	43.7	33.5	25.1	-	-	-	69.9	4.7	43.4	32.5	24.1	-	-	-
	72	66.0	4.0	52.1	43.7	35.3	26.8	-	-	64.4	4.7	51.0	42.6	34.2	25.7	-	-
	67	60.4	4.1	60.5	53.9	45.5	37.0	28.6	-	58.8	4.6	58.6	52.7	44.2	35.8	27.4	-
	62	55.1	3.8	55.1	55.1	54.5	46.1	37.7	29.2	53.7	4.5	53.7	53.7	53.3	44.9	36.5	28.1
	57	55.3	3.6	55.3	55.3	57.6	49.2	40.8	32.3	53.4	4.3	53.4	53.4	55.7	47.2	38.8	30.4
2000	77	73.0	4.0	48.2	34.9	25.2	-	-	-	69.9	4.7	48.4	33.8	24.1	-	-	-
	72	67.3	4.1	54.9	45.2	35.5	25.8	-	-	64.4	4.7	53.6	43.9	34.2	24.5	-	-
	67	61.6	4.1	61.6	55.5	45.7	36.0	26.3	-	58.8	4.6	58.8	54.0	44.2	34.5	24.8	-
	62	56.3	3.8	56.3	56.3	54.8	45.1	35.4	25.7	53.7	4.5	53.7	53.7	53.3	43.6	33.9	24.2
	57	56.4	3.7	56.4	56.4	61.1	51.4	41.6	31.9	53.4	4.3	53.4	53.4	57.9	48.2	38.5	28.8
2250	72	68.2	4.2	59.5	48.4	37.4	26.3	-	-	64.6	4.9	58.0	47.0	35.9	24.8	-	-
	67	62.4	4.2	62.4	59.3	48.2	37.1	26.0	-	59.0	4.8	59.0	56.6	46.5	35.4	24.3	-
	62	57.0	3.9	57.0	57.0	56.2	45.2	34.1	23.0	53.9	4.7	53.9	53.9	53.7	42.7	31.6	20.5
	57	57.1	3.8	57.1	57.1	59.4	48.4	37.3	26.2	53.6	4.6	53.6	53.6	55.9	44.8	33.8	22.7
	2500	72	69.0	4.3	64.2	51.7	39.2	26.8	-	-	64.9	5.1	62.5	50.1	37.6	25.2	-
67		63.1	4.3	63.1	63.1	50.6	38.2	25.8	-	59.3	5.0	59.3	59.3	48.7	36.3	23.9	-
62		57.6	4.0	57.6	57.6	57.6	45.2	32.8	20.4	54.1	4.9	54.1	54.1	54.1	41.7	29.3	16.9
57		57.8	3.8	57.8	57.8	57.8	45.4	32.9	20.5	53.9	4.8	53.9	53.9	53.9	41.4	29.0	16.6
		95°F								105°F							
1500	77	69.7	5.6	37.5	30.4	23.3	-	-	-	70.6	6.1	36.5	29.4	22.3	-	-	-
	72	64.1	5.4	47.5	40.4	33.3	26.2	-	-	64.1	5.9	46.4	39.3	32.2	25.1	-	-
	67	58.5	5.2	57.5	50.4	43.3	36.2	29.0	-	57.6	5.7	56.4	49.2	42.1	35.0	27.8	-
	62	53.4	5.3	53.4	53.4	52.5	45.4	38.2	31.1	52.6	5.7	52.6	52.6	52.2	45.1	37.9	30.8
	57	52.7	5.1	52.7	52.7	52.7	45.6	38.4	31.3	53.2	5.6	53.2	53.2	51.3	44.2	37.0	29.9
1750	77	68.3	5.5	43.1	31.6	23.1	-	-	-	66.8	6.0	43.2	30.8	22.0	-	-	-
	72	62.8	5.3	49.9	41.5	33.1	24.7	-	-	60.7	5.8	48.6	40.1	31.7	23.3	-	-
	67	57.2	5.1	56.8	51.4	43.0	34.6	26.2	-	54.6	5.6	53.9	49.5	41.5	33.0	24.6	-
	62	52.2	5.2	52.2	52.2	52.2	43.7	35.3	26.9	49.8	5.6	49.8	49.8	51.9	43.5	35.1	26.7
	57	51.6	5.1	51.6	51.6	53.7	45.3	36.9	28.4	50.3	5.5	50.3	50.3	51.2	42.8	34.4	25.9
2000	77	66.8	5.4	48.6	32.7	23.0	-	-	-	63.0	5.9	49.8	32.1	21.6	-	-	-
	72	61.4	5.2	52.3	42.6	32.9	23.1	-	-	57.2	5.7	50.7	40.9	31.2	21.5	-	-
	67	56.0	5.1	56.0	52.5	42.8	33.0	23.3	-	51.5	5.6	51.5	49.8	40.8	31.1	21.4	-
	62	51.1	5.2	51.1	51.1	51.8	42.1	32.4	22.7	47.0	5.5	47.0	47.0	51.7	42.0	32.2	22.5
	57	50.5	5.0	50.5	50.5	54.8	45.0	35.3	25.6	47.4	5.4	47.4	47.4	51.1	41.4	31.7	22.0
2250	72	61.1	5.6	56.5	45.5	34.4	23.4	-	-	56.9	6.1	53.6	43.8	32.8	21.7	-	-
	67	55.7	5.4	55.7	54.0	44.8	33.7	22.7	-	51.2	5.9	51.2	50.4	42.9	31.8	20.7	-
	62	50.8	5.5	50.8	50.8	51.2	40.2	29.1	18.0	46.8	5.8	46.8	46.8	49.1	38.0	27.0	15.9
	57	50.2	5.4	50.2	50.2	52.4	41.3	30.2	19.1	47.2	5.7	47.2	47.2	49.0	38.0	26.9	15.8
	2500	72	60.8	6.0	60.8	48.4	36.0	23.6	-	-	56.6	6.4	56.6	46.7	34.3	21.9	-
67		55.4	5.8	55.4	55.4	46.8	34.4	22.0	-	51.0	6.2	51.0	51.0	44.9	32.5	20.0	-
62		50.6	5.9	50.6	50.6	50.6	38.2	25.8	13.3	46.5	6.2	46.5	46.5	46.5	34.1	21.7	9.3
57		50.0	5.7	50.0	50.0	50.0	37.5	25.1	12.7	46.9	6.1	46.9	46.9	46.9	34.5	22.1	9.7

TABLE 8: COOLING CAPACITIES - 5 TON (BHP060) (Continued)

Air on Evaporator Coil		Temperature of Air on Condenser Coil																	
CFM	WB (°F)	Total Capacity ¹ (MBh)	Total Input (kW) ²	Sensible Capacity (MBh)						Total Capacity ¹ (MBh)	Total Input (kW) ²	Sensible Capacity (MBh)							
				Return Dry Bulb (°F)								Return Dry Bulb (°F)							
				90	85	80	75	70	65			90	85	80	75	70	65		
		115°F												125°F					
1500	77	71.4	6.6	35.6	28.4	21.3	-	-	-	72.2	7.1	34.6	27.4	20.3	-	-	-		
	72	64.1	6.4	45.4	38.2	31.1	24.0	-	-	64.1	6.9	44.3	37.1	30.0	22.9	-	-		
	67	56.8	6.2	55.2	48.0	40.9	33.8	26.7	-	55.9	6.8	54.0	46.8	39.7	32.6	25.5	-		
	62	51.9	6.1	51.9	51.9	51.9	44.8	37.6	30.5	51.2	6.4	51.2	51.2	51.2	44.5	37.3	30.2		
	57	53.6	6.0	53.6	53.6	49.9	42.8	35.7	28.5	54.1	6.4	54.1	54.1	48.5	41.4	34.3	27.1		
1750	77	65.3	6.5	43.3	30.0	20.8	-	-	-	63.8	7.0	43.4	29.2	19.6	-	-	-		
	72	58.6	6.3	47.2	38.8	30.3	21.9	-	-	56.5	6.8	45.8	37.4	29.0	20.6	-	-		
	67	51.9	6.2	51.1	47.5	39.9	31.5	23.1	-	49.2	6.7	48.3	45.6	38.4	29.9	21.5	-		
	62	47.4	6.0	47.4	47.4	51.7	43.3	34.9	26.4	45.0	6.4	45.0	45.0	45.0	43.0	34.6	26.2		
	57	49.0	5.9	49.0	49.0	48.7	40.3	31.8	23.4	47.8	6.3	47.8	47.8	46.2	37.8	29.3	20.9		
2000	77	59.1	6.4	51.0	31.6	20.3	-	-	-	55.3	6.9	52.2	31.0	18.9	-	-	-		
	72	53.1	6.3	49.0	39.3	29.6	19.9	-	-	48.9	6.8	47.4	37.7	28.0	18.2	-	-		
	67	47.0	6.1	47.0	47.0	38.9	29.2	19.5	-	42.6	6.6	42.6	42.6	37.0	27.3	17.6	-		
	62	43.0	5.9	43.0	43.0	51.5	41.8	32.1	22.4	38.9	6.3	38.9	38.9	38.9	38.9	31.9	22.2		
	57	44.4	5.9	44.4	44.4	47.5	37.8	28.0	18.3	41.4	6.3	41.4	41.4	41.4	34.1	24.4	14.7		
2250	72	52.8	6.5	50.7	42.2	31.1	20.0	-	-	48.6	7.0	47.8	40.5	29.4	18.4	-	-		
	67	46.8	6.4	46.8	46.8	40.9	29.8	18.8	-	42.3	6.8	42.3	42.3	39.0	27.9	16.8	-		
	62	42.7	6.2	42.7	42.7	47.0	35.9	24.9	13.8	38.7	6.5	38.7	38.7	38.7	33.8	22.8	11.7		
	57	44.2	6.1	44.2	44.2	45.7	34.6	23.6	12.5	41.2	6.5	41.2	41.2	41.2	31.3	20.2	9.2		
	2500	72	52.5	6.8	52.5	45.1	32.6	20.2	-	-	48.3	7.2	48.3	43.4	30.9	18.5	-	-	
67		46.5	6.6	46.5	46.5	42.9	30.5	18.1	-	42.0	7.1	42.0	42.0	41.0	28.5	16.1	-		
62		42.5	6.4	42.5	42.5	42.5	30.1	17.6	5.2	38.4	6.7	38.4	38.4	38.4	26.0	13.6	1.2		
57		43.9	6.4	43.9	43.9	43.9	31.5	19.1	6.7	40.9	6.7	40.9	40.9	40.9	28.5	16.1	3.6		

1. These capacities are Net Capacities.
2. These ratings include the compressor, condenser fan and supply air blower motors.

TABLE 9: HEATING CAPACITIES - 2 TON (BHP024)

CFM	RETURN AIR °F	CAP ¹ & KW ²	OUTDOOR AIR TEMPERATURE, °F (72% RH)							
			-10	0	10	20	30	40	50	60
600	55	MBH	10.22	11.75	13.60	15.84	18.55	21.83	25.80	30.60
		KW	1.21	1.31	1.40	1.49	1.59	1.68	1.77	1.87
	70	MBH	7.32	8.85	10.70	12.94	15.66	18.93	22.90	27.70
		KW	1.36	1.46	1.55	1.64	1.74	1.83	1.92	2.02
	80	MBH	7.21	8.74	10.59	12.83	15.54	18.82	22.79	27.59
		KW	1.42	1.52	1.61	1.70	1.80	1.89	1.98	2.08
700	55	MBH	10.21	11.74	13.60	15.84	18.55	21.83	25.80	30.60
		KW	1.22	1.31	1.41	1.50	1.59	1.69	1.78	1.87
	70	MBH	7.31	8.84	10.70	12.94	15.65	18.93	22.90	27.70
		KW	1.37	1.46	1.56	1.65	1.74	1.84	1.93	2.02
	80	MBH	7.20	8.73	10.59	12.83	15.54	18.82	22.79	27.58
		KW	1.43	1.52	1.62	1.71	1.80	1.90	1.99	2.08
800	55	MBH	10.21	11.74	13.59	15.83	18.54	21.82	25.79	30.59
		KW	1.23	1.32	1.41	1.51	1.60	1.69	1.79	1.88
	70	MBH	7.31	8.84	10.69	12.93	15.65	18.92	22.89	27.69
		KW	1.38	1.47	1.56	1.66	1.75	1.84	1.94	2.03
	80	MBH	7.20	8.73	10.58	12.82	15.53	18.81	22.78	27.58
		KW	1.44	1.53	1.62	1.72	1.81	1.90	2.00	2.09
900	55	MBH	10.79	12.32	14.18	16.42	19.13	22.41	26.38	31.18
		KW	1.28	1.38	1.47	1.56	1.66	1.75	1.84	1.94
	70	MBH	7.89	9.42	11.28	13.52	16.23	19.51	23.48	28.28
		KW	1.43	1.53	1.62	1.71	1.81	1.90	1.99	2.09
	80	MBH	7.78	9.31	11.17	13.41	16.12	19.40	23.37	28.17
		KW	1.49	1.59	1.68	1.77	1.87	1.96	2.05	2.15
1000	55	MBH	11.38	12.91	14.76	17.00	19.72	22.99	26.96	31.76
		KW	1.34	1.43	1.53	1.62	1.71	1.81	1.90	1.99
	70	MBH	8.48	10.01	11.86	14.10	16.82	20.10	24.06	28.86
		KW	1.49	1.58	1.67	1.77	1.86	1.96	2.05	2.14
	80	MBH	8.37	9.90	11.75	13.99	16.70	19.98	23.95	28.75
		KW	1.55	1.64	1.73	1.83	1.92	2.02	2.11	2.20

1. These Capacities are net capacities - the indoor motor heat has been added.
2. These power inputs are total power inputs - the indoor motor watts have been added.

TABLE 10: HEATING CAPACITIES - 2-1/2 TON (BHP030)

CFM	RETURN AIR °F	CAP ¹ & KW ²	OUTDOOR AIR TEMPERATURE, °F (72% RH)							
			-10	0	10	20	30	40	50	60
750	55	MBH	10.88	12.81	15.08	17.74	20.88	24.56	28.88	33.96
		KW	1.85	1.92	1.99	2.06	2.13	2.20	2.27	2.34
	70	MBH	10.05	11.98	14.25	16.91	20.05	23.73	28.05	33.13
		KW	2.14	2.21	2.28	2.35	2.42	2.49	2.56	2.63
	80	MBH	9.05	10.99	13.26	15.92	19.05	22.73	27.06	32.14
		KW	2.38	2.45	2.52	2.59	2.66	2.73	2.80	2.87
875	55	MBH	11.38	13.31	15.58	18.25	21.38	25.06	29.38	34.46
		KW	1.79	1.86	1.93	2.00	2.07	2.14	2.21	2.28
	70	MBH	10.55	12.48	14.75	17.42	20.55	24.23	28.55	33.63
		KW	2.08	2.15	2.22	2.29	2.36	2.43	2.50	2.57
	80	MBH	9.56	11.49	13.76	16.43	19.56	23.24	27.56	32.64
		KW	2.32	2.39	2.46	2.53	2.60	2.67	2.74	2.81
1000	55	MBH	11.89	13.82	16.09	18.75	21.89	25.57	29.89	34.97
		KW	1.73	1.80	1.87	1.94	2.01	2.08	2.15	2.22
	70	MBH	11.06	12.99	15.26	17.92	21.06	24.74	29.06	34.14
		KW	2.02	2.09	2.16	2.23	2.30	2.37	2.44	2.51
	80	MBH	10.06	12.00	14.27	16.93	20.06	23.74	28.07	33.15
		KW	2.26	2.33	2.40	2.47	2.54	2.61	2.68	2.75
1125	55	MBH	12.93	14.86	17.13	19.80	22.93	26.61	30.94	36.01
		KW	1.81	1.88	1.95	2.02	2.09	2.16	2.23	2.30
	70	MBH	12.10	14.03	16.30	18.97	22.10	25.78	30.11	35.18
		KW	2.09	2.16	2.23	2.30	2.37	2.44	2.51	2.58
	80	MBH	11.11	13.04	15.31	17.98	21.11	24.79	29.11	34.19
		KW	2.34	2.41	2.48	2.55	2.62	2.69	2.76	2.83
1250	55	MBH	13.98	15.91	18.18	20.85	23.98	27.66	31.98	37.06
		KW	1.88	1.95	2.02	2.09	2.16	2.23	2.30	2.37
	70	MBH	13.15	15.08	17.35	20.02	23.15	26.83	31.15	36.23
		KW	2.17	2.24	2.31	2.38	2.45	2.52	2.59	2.66
	80	MBH	12.16	14.09	16.36	19.02	22.16	25.84	30.16	35.24
		KW	2.41	2.48	2.55	2.62	2.69	2.76	2.83	2.90

1. These Capacities are net capacities - the indoor motor heat has been added.
2. These power inputs are total power inputs - the indoor motor watts have been added.

TABLE 11: HEATING CAPACITIES - 3 TON (BHP036)

CFM	RETURN AIR °F	CAP ¹ & KW ²	OUTDOOR AIR TEMPERATURE, °F (72% RH)							
			-10	0	10	20	30	40	50	60
900	55	MBH	10.60	12.79	15.45	18.66	22.55	27.24	32.93	39.80
		KW	1.79	1.90	2.00	2.11	2.22	2.33	2.43	2.54
	70	MBH	9.42	11.62	14.27	17.48	21.37	26.07	31.75	38.63
		KW	2.20	2.30	2.41	2.52	2.63	2.73	2.84	2.95
	80	MBH	7.54	9.74	12.39	15.61	19.49	24.19	29.87	36.75
		KW	2.48	2.58	2.69	2.80	2.90	3.01	3.12	3.22
1050	55	MBH	11.12	13.32	15.98	19.19	23.07	27.77	33.46	40.33
		KW	1.81	1.91	2.02	2.13	2.24	2.34	2.45	2.56
	70	MBH	9.95	12.14	14.80	18.01	21.90	26.59	32.28	39.15
		KW	2.21	2.32	2.43	2.54	2.64	2.75	2.86	2.96
	80	MBH	8.07	10.27	12.92	16.13	20.02	24.72	30.40	37.28
		KW	2.49	2.60	2.71	2.81	2.92	3.03	3.13	3.24
1200	55	MBH	11.65	13.85	16.50	19.71	23.60	28.30	33.98	40.86
		KW	1.82	1.93	2.04	2.15	2.25	2.36	2.47	2.57
	70	MBH	10.48	12.67	15.33	18.54	22.42	27.12	32.81	39.68
		KW	2.23	2.34	2.45	2.55	2.66	2.77	2.87	2.98
	80	MBH	8.60	10.79	13.45	16.66	20.55	25.25	30.93	37.81
		KW	2.51	2.62	2.72	2.83	2.94	3.04	3.15	3.26
1350	55	MBH	11.97	14.16	16.82	20.03	23.92	28.61	34.30	41.17
		KW	1.80	1.91	2.02	2.12	2.23	2.34	2.44	2.55
	70	MBH	10.79	12.99	15.64	18.85	22.74	27.44	33.12	40.00
		KW	2.21	2.32	2.42	2.53	2.64	2.74	2.85	2.96
	80	MBH	8.91	11.11	13.76	16.98	20.86	25.56	31.24	38.12
		KW	2.49	2.59	2.70	2.81	2.91	3.02	3.13	3.24
1500	55	MBH	12.28	14.48	17.13	20.34	24.23	28.93	34.61	41.49
		KW	1.78	1.89	1.99	2.10	2.21	2.31	2.42	2.53
	70	MBH	11.11	13.30	15.96	19.17	23.05	27.75	33.44	40.31
		KW	2.19	2.29	2.40	2.51	2.61	2.72	2.83	2.93
	80	MBH	9.23	11.42	14.08	17.29	21.18	25.88	31.56	38.44
		KW	2.46	2.57	2.68	2.78	2.89	3.00	3.11	3.21

1. These Capacities are net capacities - the indoor motor heat has been added.
2. These power inputs are total power inputs - the indoor motor watts have been added.

TABLE 12: HEATING CAPACITIES - 3-1/2 TON (BHP042)

CFM	RETURN AIR °F	CAP ¹ & KW ²	OUTDOOR AIR TEMPERATURE, °F (72% RH)							
			-10	0	10	20	30	40	50	60
1050	55	MBH	15.40	17.99	20.97	24.40	28.37	32.94	38.22	44.30
		KW	2.41	2.50	2.60	2.69	2.79	2.88	2.98	3.07
	70	MBH	14.34	16.93	19.91	23.34	27.31	31.88	37.15	43.24
		KW	2.83	2.93	3.02	3.12	3.21	3.31	3.40	3.50
	80	MBH	13.67	16.25	19.23	22.67	26.63	31.21	36.48	42.56
		KW	3.14	3.24	3.33	3.43	3.52	3.62	3.71	3.81
1225	55	MBH	16.65	19.24	22.22	25.65	29.62	34.19	39.46	45.55
		KW	2.41	2.51	2.60	2.70	2.79	2.89	2.98	3.08
	70	MBH	15.59	18.17	21.15	24.59	28.56	33.13	38.40	44.48
		KW	2.84	2.93	3.03	3.12	3.22	3.31	3.41	3.50
	80	MBH	14.92	17.50	20.48	23.92	27.88	32.45	37.73	43.81
		KW	3.15	3.24	3.34	3.43	3.53	3.62	3.72	3.81
1400	55	MBH	17.90	20.48	23.46	26.90	30.87	35.44	40.71	46.80
		KW	2.42	2.51	2.61	2.70	2.80	2.89	2.99	3.08
	70	MBH	16.84	19.42	22.40	25.84	29.80	34.38	39.65	45.73
		KW	2.84	2.94	3.03	3.13	3.22	3.32	3.41	3.51
	80	MBH	16.17	18.75	21.73	25.17	29.13	33.70	38.98	45.06
		KW	3.15	3.25	3.34	3.44	3.53	3.63	3.72	3.81
1575	55	MBH	18.40	20.98	23.96	27.40	31.37	35.94	41.21	47.30
		KW	2.44	2.54	2.63	2.73	2.82	2.91	3.01	3.10
	70	MBH	17.34	19.92	22.90	26.34	30.30	34.88	40.15	46.23
		KW	2.87	2.96	3.06	3.15	3.24	3.34	3.43	3.53
	80	MBH	16.67	19.25	22.23	25.67	29.63	34.20	39.48	45.56
		KW	3.17	3.27	3.36	3.46	3.55	3.65	3.74	3.84
1750	55	MBH	18.90	21.48	24.46	27.90	31.87	36.44	41.71	47.80
		KW	2.46	2.56	2.65	2.75	2.84	2.94	3.03	3.13
	70	MBH	17.84	20.42	23.40	26.84	30.80	35.38	40.65	46.73
		KW	2.89	2.98	3.08	3.17	3.27	3.36	3.46	3.55
	80	MBH	17.17	19.75	22.73	26.17	30.13	34.70	39.98	46.06
		KW	3.20	3.29	3.39	3.48	3.57	3.67	3.76	3.86

1. These Capacities are net capacities - the indoor motor heat has been added.
2. These power inputs are total power inputs - the indoor motor watts have been added.

TABLE 13: HEATING CAPACITIES - 4 TON (BHP048)

CFM	RETURN AIR °F	CAP ¹ & KW ²	OUTDOOR AIR TEMPERATURE, °F (72% RH)							
			-10	0	10	20	30	40	50	60
1200	55	MBH	13.91	17.10	21.02	25.86	31.82	39.17	48.23	59.39
		KW	2.34	2.57	2.80	3.02	3.25	3.48	3.70	3.93
	70	MBH	11.26	14.45	18.37	23.21	29.17	36.52	45.58	56.74
		KW	2.73	2.95	3.18	3.41	3.63	3.86	4.09	4.31
	80	MBH	9.68	12.86	16.79	21.62	27.59	34.93	43.99	55.15
		KW	3.07	3.29	3.52	3.75	3.97	4.20	4.43	4.65
1400	55	MBH	15.13	18.31	22.24	27.08	33.04	40.39	49.45	60.61
		KW	2.37	2.60	2.83	3.06	3.28	3.51	3.74	3.96
	70	MBH	12.48	15.67	19.59	24.43	30.39	37.74	46.80	57.96
		KW	2.76	2.99	3.21	3.44	3.67	3.89	4.12	4.35
	80	MBH	10.89	14.08	18.01	22.84	28.81	36.15	45.21	56.37
		KW	3.10	3.33	3.55	3.78	4.01	4.23	4.46	4.69
1600	55	MBH	16.35	19.53	23.46	28.30	34.26	41.61	50.66	61.83
		KW	2.41	2.63	2.86	3.09	3.32	3.54	3.77	4.00
	70	MBH	13.70	16.89	20.81	25.65	31.61	38.96	48.02	59.18
		KW	2.79	3.02	3.25	3.47	3.70	3.93	4.15	4.38
	80	MBH	12.11	15.30	19.22	24.06	30.02	37.37	46.43	57.59
		KW	3.13	3.36	3.59	3.81	4.04	4.27	4.49	4.72
1800	55	MBH	16.99	20.17	24.10	28.94	34.90	42.25	51.30	62.47
		KW	2.45	2.68	2.91	3.14	3.36	3.59	3.82	4.04
	70	MBH	14.34	17.53	21.45	26.29	32.25	39.60	48.66	59.82
		KW	2.84	3.07	3.29	3.52	3.75	3.97	4.20	4.43
	80	MBH	12.75	15.94	19.86	24.70	30.66	38.01	47.07	58.23
		KW	3.18	3.41	3.63	3.86	4.09	4.31	4.54	4.77
2000	55	MBH	17.63	20.81	24.74	29.58	35.54	42.89	51.94	63.11
		KW	2.50	2.73	2.96	3.18	3.41	3.64	3.86	4.09
	70	MBH	14.98	18.17	22.09	26.93	32.89	40.24	49.30	60.46
		KW	2.89	3.11	3.34	3.57	3.79	4.02	4.25	4.47
	80	MBH	13.39	16.58	20.50	25.34	31.30	38.65	47.71	58.87
		KW	3.23	3.45	3.68	3.91	4.13	4.36	4.59	4.81

1. These Capacities are net capacities - the indoor motor heat has been added.
2. These power inputs are total power inputs - the indoor motor watts have been added.

TABLE 14: HEATING CAPACITIES - 5 TON (BHP060)

CFM	RETURN AIR °F	CAP ¹ & KW ²	OUTDOOR AIR TEMPERATURE, °F (72% RH)							
			-10	0	10	20	30	40	50	60
1500	55	MBH	15.48	19.33	23.99	29.63	36.47	44.76	54.81	66.99
		KW	2.80	3.17	3.54	3.91	4.28	4.65	5.02	5.39
	70	MBH	14.28	18.13	22.79	28.43	35.27	43.56	53.61	65.79
		KW	3.36	3.73	4.09	4.46	4.83	5.20	5.57	5.94
	80	MBH	12.41	16.26	20.92	26.56	33.40	41.69	51.74	63.92
		KW	3.74	4.11	4.48	4.85	5.22	5.59	5.96	6.33
1750	55	MBH	17.42	21.26	25.92	31.57	38.41	46.70	56.74	68.92
		KW	2.60	2.97	3.34	3.71	4.08	4.45	4.82	5.19
	70	MBH	16.22	20.06	24.72	30.37	37.21	45.50	55.54	67.72
		KW	3.16	3.53	3.90	4.27	4.64	5.01	5.38	5.75
	80	MBH	14.35	18.19	22.85	28.50	35.34	43.63	53.67	65.85
		KW	3.54	3.91	4.28	4.65	5.02	5.39	5.76	6.13
2000	55	MBH	19.35	23.19	27.85	33.50	40.34	48.63	58.68	70.85
		KW	2.40	2.77	3.14	3.51	3.88	4.25	4.62	4.99
	70	MBH	18.15	21.99	26.65	32.30	39.14	47.43	57.48	69.65
		KW	2.96	3.33	3.70	4.07	4.44	4.81	5.18	5.55
	80	MBH	16.28	20.12	24.78	30.43	37.27	45.56	55.61	67.78
		KW	3.35	3.72	4.08	4.45	4.82	5.19	5.56	5.93
2250	55	MBH	18.43	22.27	26.93	32.58	39.42	47.71	57.76	69.93
		KW	2.60	2.97	3.34	3.71	4.08	4.45	4.82	5.19
	70	MBH	17.23	21.07	25.73	31.38	38.22	46.51	56.56	68.73
		KW	3.16	3.53	3.90	4.27	4.64	5.01	5.38	5.75
	80	MBH	15.36	19.20	23.86	29.51	36.35	44.64	54.69	66.86
		KW	3.54	3.91	4.28	4.65	5.02	5.39	5.76	6.13
2500	55	MBH	17.51	21.35	26.01	31.66	38.50	46.79	56.84	69.01
		KW	2.80	3.17	3.54	3.91	4.28	4.65	5.02	5.39
	70	MBH	16.31	20.15	24.81	30.46	37.30	45.59	55.64	67.81
		KW	3.36	3.73	4.10	4.47	4.84	5.21	5.58	5.95
	80	MBH	14.44	18.28	22.94	28.59	35.43	43.72	53.77	65.94
		KW	3.74	4.11	4.48	4.85	5.22	5.59	5.96	6.33

1. These Capacities are net capacities - the indoor motor heat has been added.
2. These power inputs are total power inputs - the indoor motor watts have been added.

TABLE 15: SIDE & BOTTOM SUPPLY AIR BLOWER PERFORMANCE

Size (Tons)	Blower Speed	External Static Pressure (Inch Water Gauge)														
		0.2			0.4			0.6			0.8			1.0		
		CFM	W	RPM	CFM	W	RPM	CFM	W	RPM	CFM	W	RPM	CFM	W	RPM
024	Low (1)	721	82	600	611	97	705	-	-	-	-	-	-	-	-	-
	Low/Medium (2)	769	93	628	694	112	730	610	126	832	-	-	-	-	-	-
	Medium (3)	882	131	704	812	147	797	736	162	889	651	177	979	-	-	-
	Medium/High (4)	971	171	773	916	188	857	851	205	939	775	219	1019	681	230	1097
	High (5)	-	-	-	-	-	-	957	249	982	887	261	1052	788	266	1120
030	Low (1)	828	110	673	759	125	771	-	-	-	-	-	-	-	-	-
	Low/Medium (2)	991	168	754	934	187	839	868	205	922	783	221	1003	-	-	-
	Medium (3)	1091	214	807	1041	234	883	983	253	958	910	269	1033	785	273	1106
	Medium/High (4)	1189	269	861	1144	288	927	1091	305	994	1027	318	1061	912	316	1132
	High (5)	-	-	-	1235	347	970	1186	360	1028	1125	368	1086	1007	352	1147
036	Low (1)	1025	158	769	906	175	856	-	-	-	-	-	-	-	-	-
	Low/Medium (2)	1214	237	764	1125	260	839	1034	283	913	942	307	987	-	-	-
	Medium (3)	1370	305	779	1276	330	846	1179	354	913	1078	377	981	971	397	1048
	Medium/High (4)	-	-	-	1416	413	872	1314	436	932	1206	454	993	1083	460	1051
	High (5)	-	-	-	-	-	-	1441	530	970	1326	538	1022	1182	521	1070
042	Low (1)	1241	221	702	1151	245	778	1058	268	853	-	-	-	-	-	-
	Low/Medium (2)	1406	299	759	1325	324	826	1242	349	893	1158	373	959	1072	396	1025
	Medium (3)	1536	376	808	1461	403	869	1384	427	928	1305	449	988	1223	468	1046
	Medium/High (4)	1656	466	858	1584	492	912	1509	515	966	1430	533	1019	1344	542	1070
	High (5)	-	-	-	1687	590	955	1611	610	1004	1527	620	1051	1428	615	1097
048	Low (1)	1342	249	717	1250	273	789	-	-	-	-	-	-	-	-	-
	Low/Medium (2)	1596	397	817	1513	422	875	1432	447	934	1354	474	995	1276	501	1058
	Medium (3)	1705	476	858	1624	501	911	1545	526	966	1466	549	1021	1386	571	1077
	Medium/High (4)	1806	561	895	1726	587	945	1646	610	995	1564	628	1046	1476	639	1096
	High (5)	1898	652	929	1819	679	977	1736	698	1023	1646	709	1069	1547	706	1112
060	Low (1)	1580	394	859	1504	420	917	-	-	-	-	-	-	-	-	-
	Low/Medium (2)	1614	419	874	1540	446	931	-	-	-	-	-	-	-	-	-
	Medium (3)	1733	508	924	1663	536	976	1588	559	1026	1501	572	1072	-	-	-
	Medium/High (4)	2003	737	1030	1922	746	1069	1829	746	1104	1712	728	1134	1528	659	1146
	High (5)	2214	968	1104	2089	918	1121	1949	859	1136	1785	787	1148	1576	689	1154

TABLE 16: ADDITIONAL STATIC RESISTANCE

DESCRIPTION	RESISTANCE, IWG															
	CFM															
	500	600	700	800	900	1,000	1,100	1,200	1,300	1,400	1,500	1,600	1,700	1,800	1,900	2,000
Wet Indoor Coil	0.01	0.01	0.01	0.02	0.01	0.02	0.03	0.04	0.04	0.03	0.04	0.04	0.05	0.05	0.06	0.07
Economizer	0.00	0.00	0.00	0.01	0.01	0.01	0.01	0.02	0.03	0.04	0.05	0.06	0.07	0.07	0.08	0.08
Filter/Frame Kit	0.01	0.02	0.02	0.02	0.02	0.02	0.03	0.03	0.03	0.03	0.04	0.05	0.05	0.06	0.06	0.07
Electric Heat	0.02	0.03	0.03	0.03	0.04	0.04	0.05	0.06	0.07	0.08	0.09	0.10	0.01	0.11	0.11	0.12

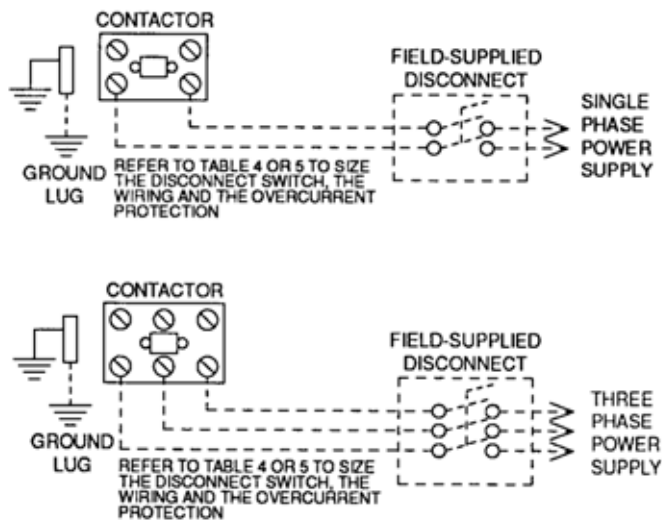
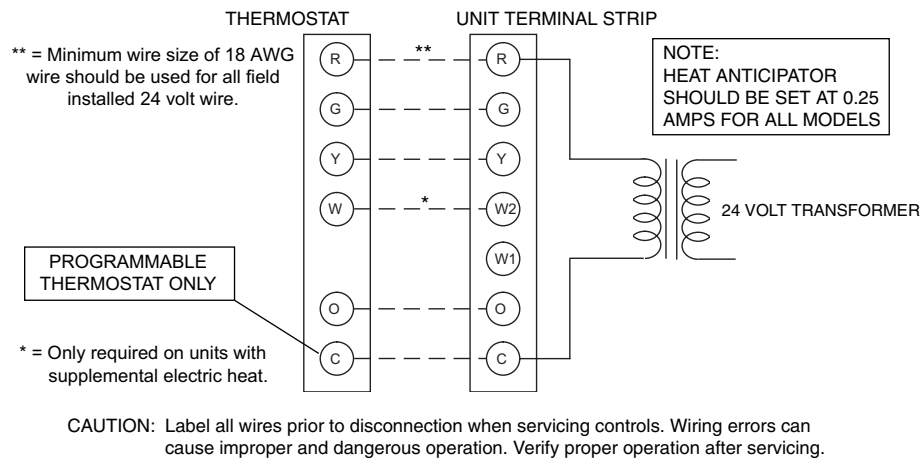

FIGURE 2 - TYPICAL FIELD WIRING DIAGRAM

TABLE 17: ELECTRICAL DATA (13 SEER HEAT PUMP / ELECTRIC HEAT)

Size (Tons)	Volt	Compressors (each)			OD Fan Motors (each)	Supply Blower Motor	Electric Heat Option				MCA ¹ (Amps)	Max Fuse ² / Breaker ³ Size (Amps)
		RLA	LRA	MCC			FLA	FLA	Model	kW		
024	208/230-1-60	9.3	57	15	1.2	4.1	None	-	-	-	16.9	25
							2NH04500506	3.8/5	1	18.1/20.8	39.5/43	40/45
							2NH04500706	5.6/7.5	2	27.1/31.3	50.8/56	60/60
							2NH04501006	7.5/10	2	36.1/41.7	62.1/69	70/70
030	208/230-1-60	13.4	73	21	1.2	4.1	None	-	-	-	22.1	30
							2NH04500506	3.8/5	1	18.1/20.8	44.6/48.1	50/50
							2NH04500706	5.6/7.5	2	27.1/31.3	55.9/61.1	60/70
							2NH04501006	7.5/10	2	36.1/41.7	67.2/74.1	70/80
	208/230-3-60	9.0	63	14	1.2	4.1	None	-	-	-	16.6	20
							2NH04501025	7.5/10	1	20.8/24.1	42.6/46.6	45/50
							2NH04501525	11.3/15	1	31.3/36.1	55.6/61.7	60/70
							None	-	-	-	8.5	15
460-3-60	4.5	31	7	0.8	2.1	2NH04501046	10	1	12	23.5	25	
						2NH04501546	15	1	18	31	35	

TABLE 17: ELECTRICAL DATA (13 SEER HEAT PUMP / ELECTRIC HEAT) (Continued)

Size (Tons)	Volt	Compressors (each)			OD Fan Motors (each)	Supply Blower Motor	Electric Heat Option				MCA ¹ (Amps)	Max Fuse ² / Breaker ³ Size (Amps)
		RLA	LRA	MCC	FLA	FLA	Model	kW	Stages	Amps		
036	208/230-1-60	15.4	88	24	1.2	6.0	None	-	-	-	26.5	35
							2NH04500506	3.8/5	1	18.1/20.8	49/52.5	50/60
							2NH04500706	5.6/7.5	2	27.1/31.3	60.3/65.5	70/70
							2NH04501006	7.5/10	2	36.1/41.7	71.6/78.5	80/80
	208/230-3-60	10.2	77	16	1.2	6.0	2NH04501506	11.3/15	2	54.2/62.5	94.2/104.6	100/110
							None	-	-	-	20	25
							2NH04501025	7.5/10	1	20.8/24.1	46/50	50/60
							2NH04501525	11.3/15	1	31.3/36.1	59/65.1	60/70
	460-3-60	5.1	39	8	0.8	3.0	None	-	-	-	10.1	15
							2NH04501046	10	1	12	25.2	30
							2NH04501546	15	1	18	32.7	35
	575-3-60	4.2	31	7	0.6	2.4	None	-	-	-	8.3	15
2NH04501058							10	1	9.6	20.3	25	
2NH04501558							15	1	14.4	26.3	30	
042	208/230-1-60	16.0	86	24	1.2	6.0	None	-	-	-	27.2	35
							2NP04501006	7.5/10	2	36.1/41.7	72.3/78.5	80/80
							2NP04501506	11.3/15	2	54.2/62.5	94.9/104.6	100/110
							2ND04501506	3.8/5	1	18.1/20.8	49.8/52.5	60/60
	7.5/10	1	36.1/41.7	72.3/78.5	80/80							
	208/230-3-60	12.0	84	18	1.2	6.0	None	-	-	-	22.2	30
							2NP04501025	7.5/10	1	20.8/24.1	48.3/51.6	50/60
							2NP04501525	11.3/15	1	31.3/36.1	61.3/66.7	70/70
	460-3-60	5.8	42	9	0.8	3.0	None	-	-	-	11	15
							2NP04501046	10	1	12	26	30
							2NP04501546	15	1	18	33.6	35
	575-3-60	5.1	34	8	0.6	2.4	None	-	-	-	9.4	15
2NP04501058							10	1	9.6	21.4	25	
2NP04501558							15	1	14.4	27.4	30	
048	208/230-1-60	23.4	126	37	1.2	6.0	None	-	-	-	36.5	45
							2NP04501006	7.5/10	2	36.1/41.7	81.6/88.5	90/100
							2NP04501506	11.3/15	2	54.2/62.5	104.2/114.6	110/125
							2NP04502006	15/20	2	72.2/83.3	126.7/140.6	150/150
	208/230-3-60	12.9	93	20	1.2	6.0	2NP04502506	18.8/25	2	90.3/104.2	149.3/166.7	150/175
							None	-	-	-	23.3	30
							2NP04501025	7.5/10	1	20.8/24.1	49.4/53.4	50/60
							2NP04501525	11.3/15	1	31.3/36.1	62.4/68.4	70/70
	460-3-60	6.4	47	10	0.8	3.0	2NP04502025	15/20	2	41.7/48.1	75.4/83.5	80/90
							2NP04502525	18.8/25	2	52.1/60.1	88.5/98.5	90/100
							None	-	-	-	11.8	15
							2NP04501046	10	1	12	26.8	30
575-3-60	5.1	37	8	0.6	2.4	2NP04501546	15	1	18	34.4	35	
						2NP04502046	20	2	24.1	41.9	45	
						2NP04502546	25	2	30.1	49.4	50	
						None	-	-	-	9.4	15	
208/230-1-60	25.0	150	39	2.3	7.6	2NP04501058	10	1	9.6	21.4	25	
						2NP04501558	15	1	14.4	27.4	30	
						2NH04502058	20	2	19.2	33.4	35	
						2NH04502558	25	2	24.1	39.4	40	
060	208/230-1-60	25.0	150	39	2.3	7.6	None	-	-	-	41.2	50
							2NP04501006	7.5/10	2	36.1/41.7	86.3/93.2	100/100
							2NP04501506	11.3/15	2	54.2/62.5	108.9/119.3	110/125
							2NH04502006	15/20	2	72.2/83.3	131.4/145.3	150/150
	208/230-3-60	17.3	123	27	2.3	7.6	2NP04502506	18.8/25	2	90.3/104.2	154/171.4	175/175
							None	-	-	-	31.5	40
							2NH04501025	7.5/10	1	20.8/24.1	57.6/61.6	60/70
							2NH04501525	11.3/15	1	31.3/36.1	70.6/76.6	80/80
	460-3-60	8.4	70	13	1.3	3.8	2NH04502025	15/20	2	41.7/48.1	83.6/91.7	90/100
							2NH04502525	18.8/25	2	52.1/60.1	96.7/106.7	100/110
							None	-	-	-	15.6	20
							2NP04501046	10	1	12	30.6	35
575-3-60	7.0	53	11	1.1	3.0	2NH04501546	15	1	18	38.2	40	
						2NH04502046	20	2	24.1	45.7	50	
						2NP04502546	25	2	30.1	53.2	60	
						None	-	-	-	12.9	15	
208/230-1-60	7.0	53	11	1.1	3.0	2NH04501058	10	1	9.6	24.9	25	
						2NH04501558	15	1	14.4	30.9	35	
						2NH04502058	20	2	19.2	36.9	40	
						2NH04502558	25	2	24.1	42.9	45	

1. Minimum Circuit Ampacity.
2. Maximum Over Current Protection per standard UL 1995.
3. Fuse or HACR circuit breaker size installed at factory or field installed.

TABLE 18: APPLICATION DATA

MODEL		BHP					
		024	030	036	042	048	060
MINIMUM AIR FLOW (CFM)	COOLING	800	1000	1050	1300	1500	1500
	HEATING	800	1000	1050	1400	1400	1500
MAXIMUM AIR FLOW (CFM)	COOLING	900	1125	1200	1400	1600	2050
	HEATING	900	1125	1200	1500	1600	2050
MINIMUM OPERATING TEMPERATURE IN COOLING MODE (AMBIENT, °F)		45	45	45	45	45	45
MINIMUM MIXED AIR IN COOLING MODE (RETURN AIR, DB °F/WB °F)		68 / 57	68 / 57	68 / 57	68 / 57	68 / 57	68 / 57
MINIMUM MIXED AIR IN HEATING MODE (RETURN AIR, °F)		55	55	55	55	55	55

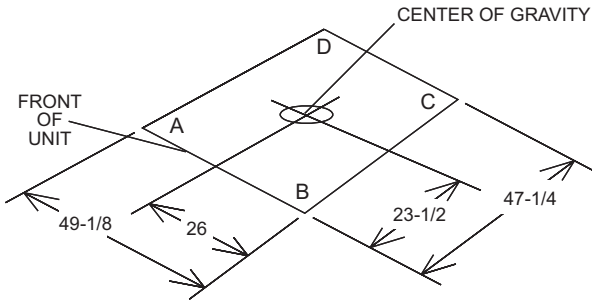

UNIT SIZE	SHIPPING WEIGHT	OPERATING WEIGHT	CORNER WEIGHTS			
			A	B	C	D
024	356	351	97	93	81	84
030	353	348	96	93	81	84
036	388	383	106	102	89	92
042	440	435	120	115	101	104
048	485	480	132	127	111	115
060	495	490	135	130	113	117

FIGURE 3 - CENTER OF GRAVITY AND WEIGHTS

CLEARANCES

UNIT CLEARANCES (MINIMUM)	
Front	12"
Back	0"
Left Side (Filter Access)	24"
Right Side	24"
Below Unit ¹	0"
Above Unit ²	36" (For Condenser Air Discharge)

1. Units may be installed on combustible floors made from wood or class A, B or C roof covering.
2. Units must be installed outdoors. Overhanging structures or shrubs should not obstruct outdoor air discharge outlet.

NOTE: FOR UNITS APPLIED WITH A ROOF CURB, THE MINIMUM CLEARANCE MAY BE REDUCED FROM 1 INCH TO 1/2 INCH BETWEEN COMBUSTIBLE ROOF CURB MATERIAL AND THE SUPPLY DUCT.

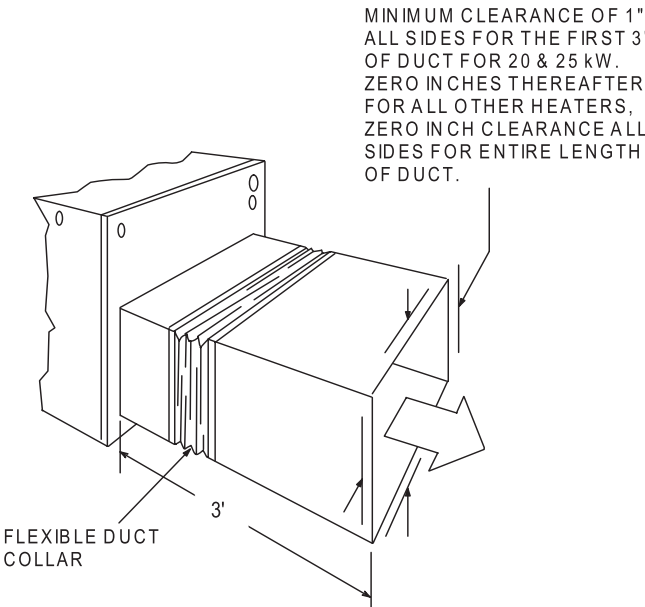

FIGURE 4 - UNIT CLEARANCES

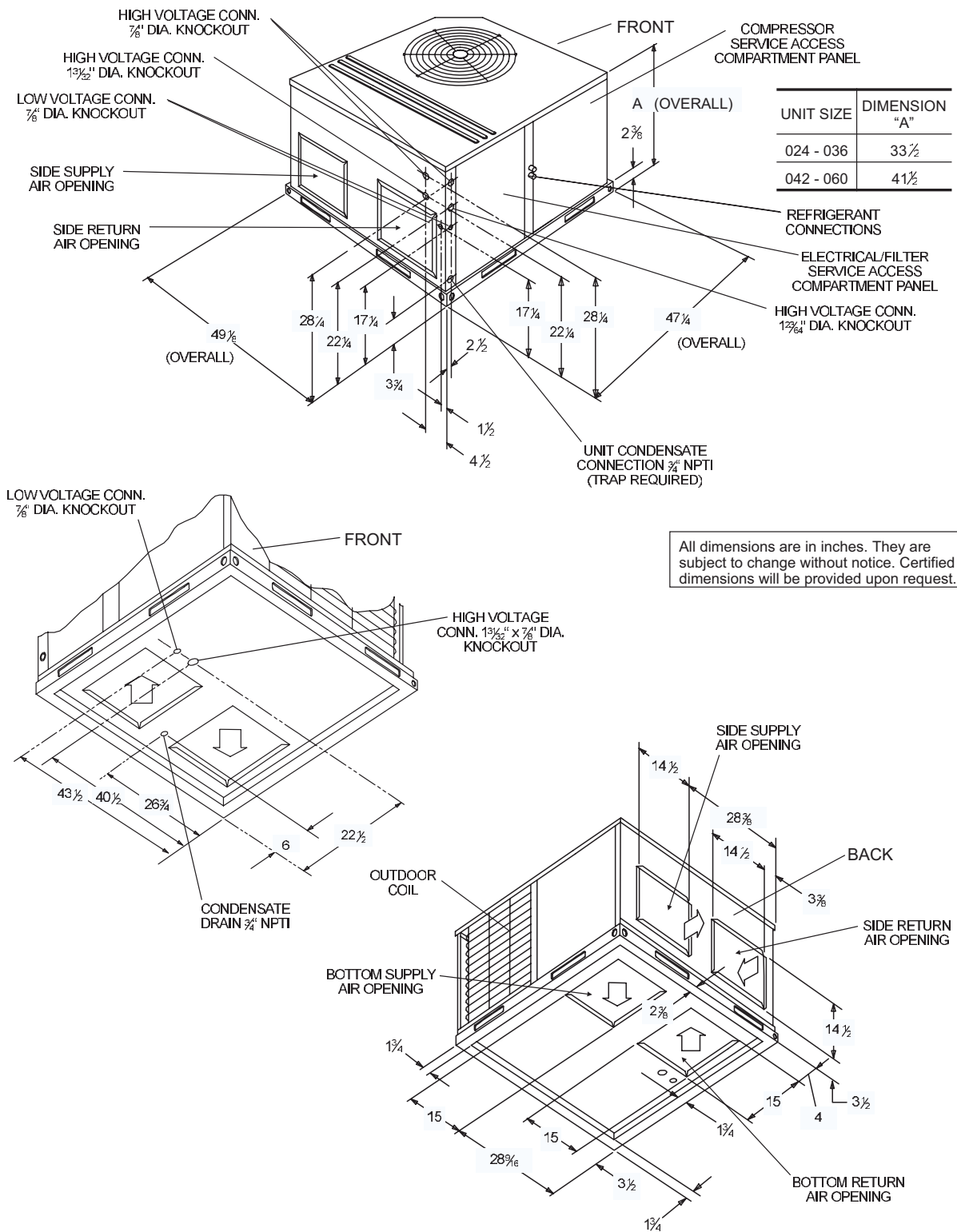
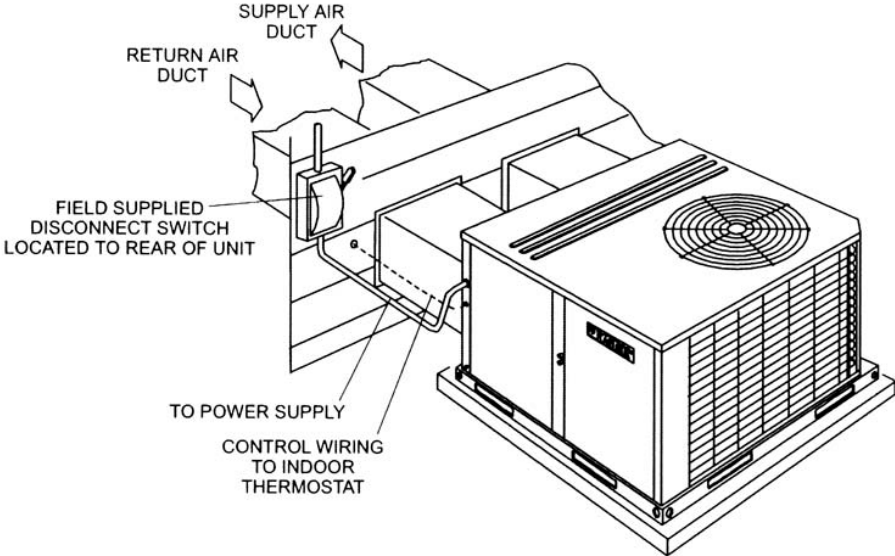

FIGURE 5 - UNIT DIMENSIONS

TYPICAL SLAB ON GROUND INSTALLATION



TYPICAL ROOF CURB INSTALLATION

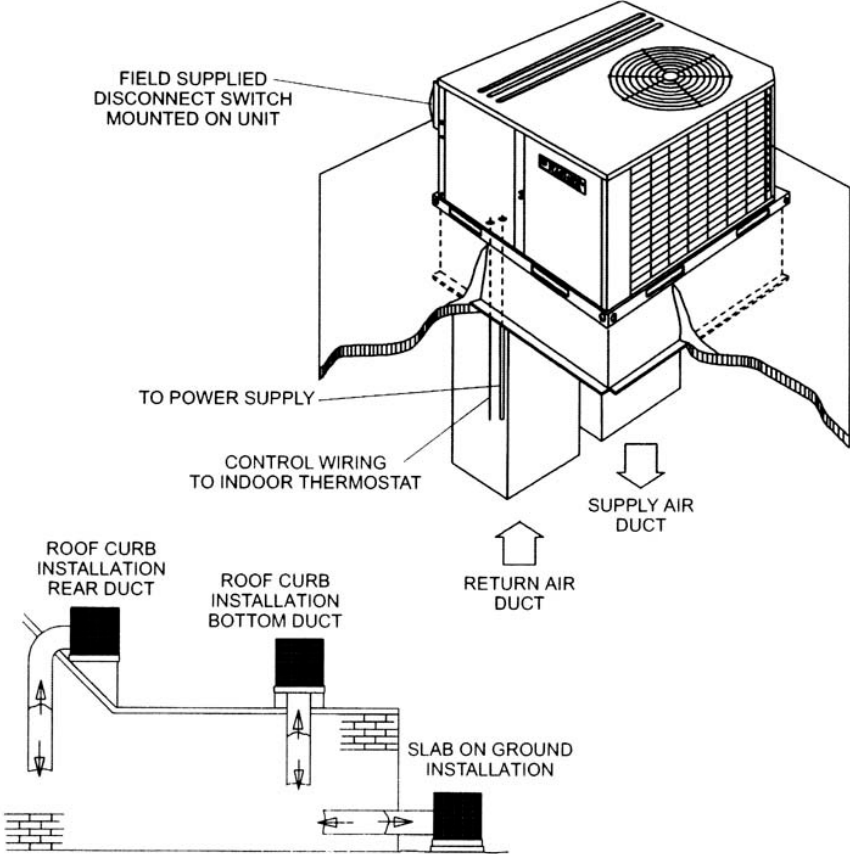
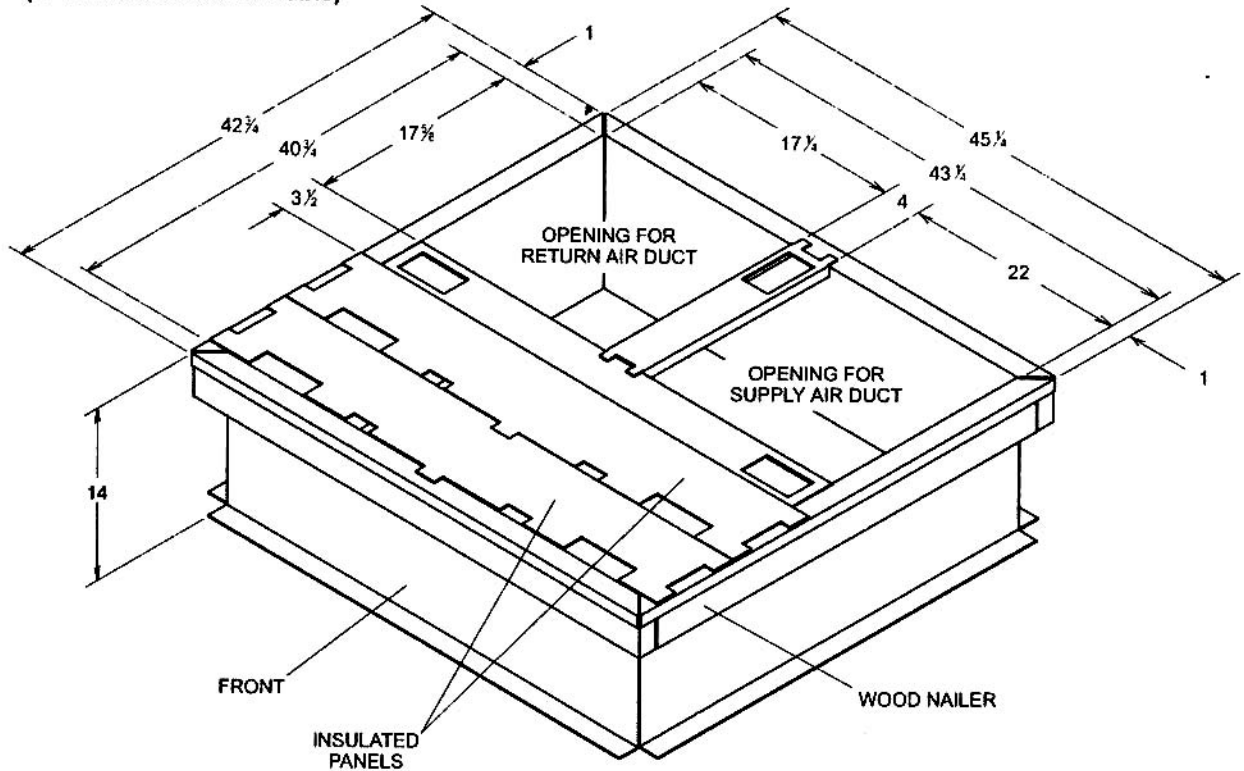

FIGURE 6 - TYPICAL APPLICATIONS

(8" roof curb also available)



RECOMMENDED DUCT SIZE	
SUPPLY AIR DUCT	17 1/2" x 21 1/2"
RETURN AIR DUCT	17 1/2" x 16 3/4"

ROOF CURB APPLICATION

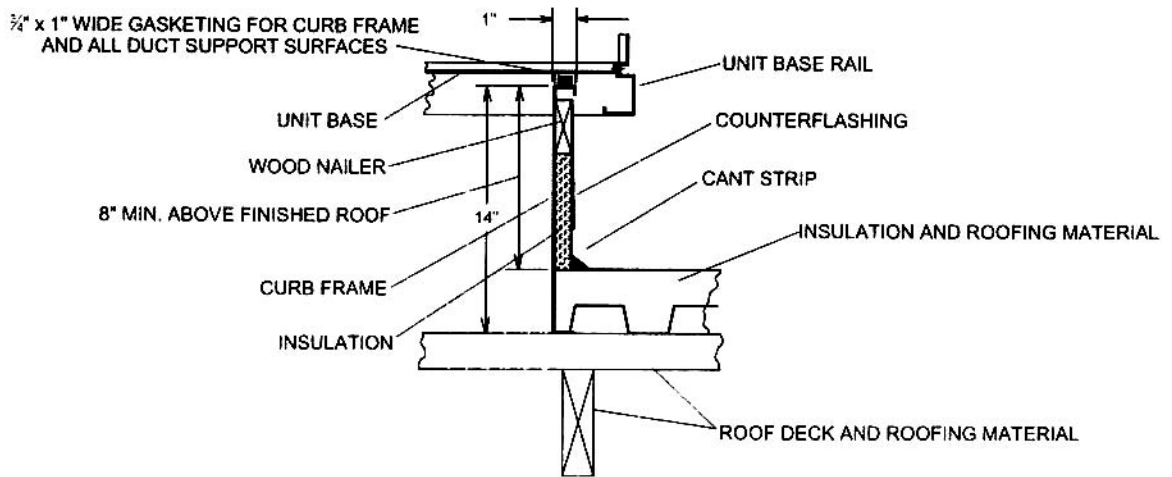

FIGURE 7 - ROOF CURB DIMENSIONS

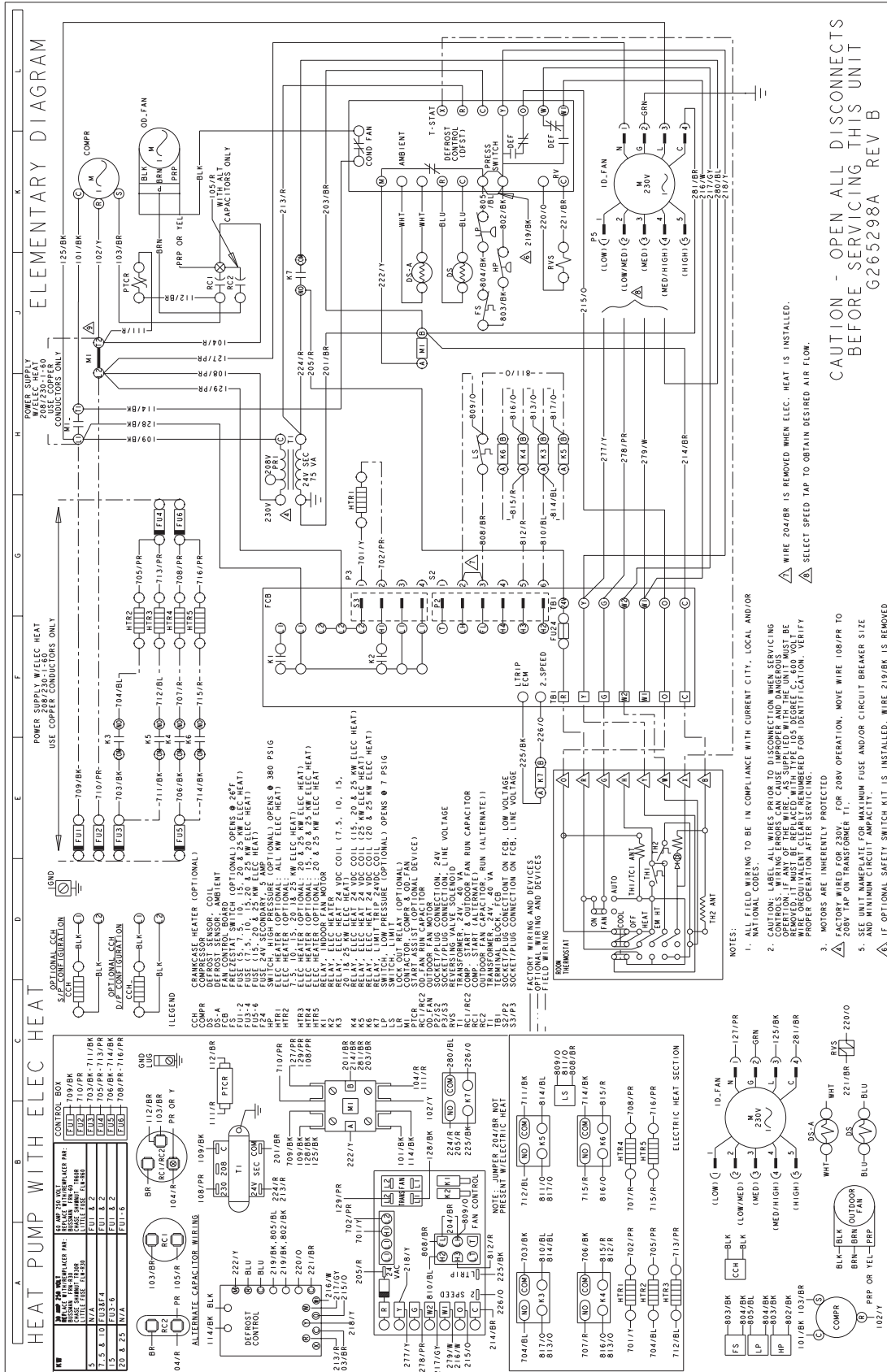

FIGURE 8 - TYPICAL WIRING DIAGRAM (208/230-1-60 POWER SUPPLY)

MECHANICAL SPECIFICATIONS

GENERAL DESCRIPTION

Units shall be factory-assembled, single packaged, Heat Pumps, designed for outdoor mounted installation. Units shall have minimum SEER ratings of 13.0. They shall have built in, equal size, field convertible duct connections for down discharge supply/return or horizontal discharge supply/return.

The units shall be factory wired, piped, charged with R-22 refrigerant and factory tested prior to shipment. All unit wiring shall be both numbered and color coded.

All units shall be manufactured in a facility certified to ISO 9001 standards, and the cooling performance shall be rated in accordance with DOE and ARI test procedures. Units shall be classified to UL 1995/CAN/CSA No. 236-M90 conditions.

UNIT CABINET

1. Unit cabinet shall be constructed of G90 galvanized steel, with exterior surfaces coated with a non-chalking, powered paint finish, certified at 1000 hours salt spray test per ASTM-B117 standards.
2. The unit top shall be a single piece "Water Shed" design, with drip edges and no-seam corners to provide optimum water integrity.
3. Unit shall have a rigidly mounted condenser coil guard to provide protection from objects and personnel after installation.
4. Indoor blower section shall be insulated with up to 3/4" thick, aluminum, foil faced insulation, fastened to prevent insulation from entering the air stream.
5. Cabinet panels shall be "large" size, easily removable for servicing and maintenance, with built-in lift handles.
6. Unit shall be built on a formed, "Super-Structure" design base pan, with embossments at critical points to add strength, rigidity and aid in minimizing sound.
7. Full perimeter base rails shall be provided to assure reliable transit of equipment, overhead rigging, fork truck access and proper sealing on roof curb applications. Base rails shall be removable, when required, to lower unit height.

8. Filters shall be furnished and be accessible through a removable access door, sealed air tight. (Single phase models - accessory kit available. Three phase models - standard from factory.)
9. Units vertical discharge and return duct configuration shall be designed to fit between standard 24" O.C. beams without modification to building structure, duct work and base unit.
10. Condensate pan shall be internally sloped and conform to ASHRAE 62-89 self-draining standards, with 3/4" NPTI copper, ridged mount connection.

INDOOR (SUPPLY) FAN ASSEMBLY

1. Fan shall be direct drive, 5 speed design.
2. Fan wheel shall be double-inlet type with forward-curved blades, dynamically balanced to operate smoothly throughout the entire range of operation. Airflow design shall be constant air volume.
3. Bearings shall be sealed and permanently lubricated for longer life and no maintenance.
4. Fan assembly shall be "Slip Track" (slide-out) design for easy removal and cleaning.

OUTDOOR FAN ASSEMBLY

1. The outdoor fan shall be of the direct-driven propeller type, discharge air vertically, have aluminum blades riveted to corrosion resistant steel spider bracket and shall be statically balanced for smooth operation.
2. The outdoor fan motor shall be totally enclosed with permanently lubricated bearings and internally protected against overload conditions.

REFRIGERANT COMPONENTS

1. Compressors:
 - A. Shall be fully hermetic type, direct drive, internally protected with internal high-pressure relief and over temperature protection. The hermetic motor shall be suction gas cooled and have a voltage range of + or - 10% of the unit nameplate voltage.
 - B. Shall have internal isolation and sound muffling to minimize vibration and noise, and be externally isolated on a dedicated, independent mounting.

2. Coils:
- A. Evaporator and condenser coils shall have aluminum plate fins mechanically bonded to seamless internally-enhanced copper tubes with all joints brazed.
 - B. Evaporator and Condenser coils shall be of the direct expansion, draw-thru design.

3. Refrigerant Circuit and Refrigerant Safety Components shall include:

- A. Independent thermal expansion devices (TXV).
- B. Solid-core filter dryer to eliminate any foreign matter.
- C. Accessible service gage connections on both suction and discharge lines to charge, evacuate, and measure refrigerant pressure during any necessary servicing or troubleshooting, without losing charge and without disrupting condenser or evaporator air flow.
- D. The refrigeration system shall provide at least 10° F of liquid sub-cooling at design conditions.
- E. Unit shall have a suction line accumulator and automatic reversing valve.

4. Unit Controls:

- A. Unit shall contain a large, low voltage Terminal Board for easy connection of field low voltage wiring.
- B. Controls shall be mounted in a large control box with tilt-out, hinged access door, allowing easy access for trouble shooting and maintenance without affecting the normal system operation pressures.
- C. Unit shall contain a reliable demand defrost control to provide defrost. The defrost control shall also have an "X" terminal to provide a 24 volt signal for room thermostat "LED" indication of unit lockout. Plus a built in 5 minute anti-short cycle protection.

- D. Unit shall have large, easily removable panels, covering electrical controls and compressor, allowing easy access for any maintenance or servicing.

ELECTRIC HEATING SECTION

1. An electric heating section, with nickel chromium elements, shall be provided in a range of 5 thru 25 KW.
2. The heating section shall have an automatic reset primary limit control to prevent the heating element system from operating at an excessive temperature.
3. The heating section assembly shall slide out of the unit for easy maintenance and service.
4. Units with electric heating sections shall be wired for a single point power supply, with branch circuit fusing (where required).

UNIT OPERATING CHARACTERISTICS

1. Unit shall be capable of starting and running at 125° F outdoor temperature, exceeding maximum load criteria of ARI Standard 210/240.
2. The compressor, with standard controls, shall be capable of operation down to 45° F outdoor temperature.

ELECTRICAL REQUIREMENTS

All unit power wiring shall enter unit cabinet at a single factory provided location and be capable of side or bottom entry. This will minimize roof penetrations and avoid unit field modifications. Separate side and bottom openings shall be provided for the control wiring.



ISO 9001
Certified Quality
Management System